



数控磨床



PCD数控磨床



数控PCD刀具磨床  
VOLLMER QM ECO

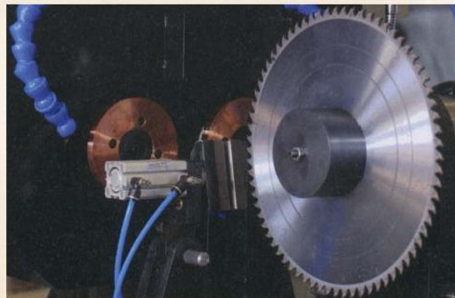

PCD齿侧刃双面同时加工

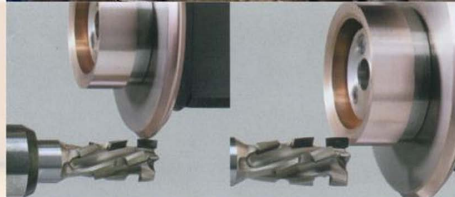

PCD五轴联动数控磨床

# 000154

## CONTENTS



01-02  
金刚石CNC螺旋铣刀系列  
Diamond CNC Spiral Milling Cutter



03  
八大金刚刀套装系列  
Diamond tool suit



04-19  
金刚石镗铣刀系列  
Carbide Spiral Cutter Series



20  
金刚石门芯板刀系列  
Diamond combination molding series



21-24  
金刚石组合线条刀系列  
Diamond Combination Molding Cutter Series



25  
金刚石橱柜门框刀系列  
Diamond Adjustable Profile Cutter For Cabinet Door Frame

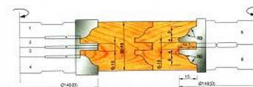

26-27  
金刚石门框刀具系列  
Diamond Door frame cutter series



28-31  
金刚石封边机刀具系列  
Diamond Sealing Side Machine Tools



32  
金刚石地板刀、粉碎刀系列  
The diamond floor knife, crushing blade series



33  
双端铣粉碎刀系列  
Double end mill crushing blade series



34  
硬质合金螺旋铣刀系列  
HARD ALLOY Spiral Milling



35  
数控榫头刀具系列  
Numerical Control Tenon Cutting Tools Series



**36**  
封边机切刀/修边锯片  
Edge banding machine cutter /saw blade



**37**  
舍弃式铝体封边机刀具系列  
The disposable aluminum edge banding machine tool series



**38-40**  
硬质合金封边机刀具系列  
The carbide edge banding machine tool series



**41-44**  
金刚石锯片系列  
Diamond saw blade series



**45-46**  
硬质合金锯片系列  
Carbide Saw series



**47-48**  
CNC开料刀  
CNC cutting tool



**49-52**  
木工排钻头系列  
Woodworking row Drill Series



**53**  
高速钢(HSS)锯片系列  
High-speed steel (HSS) saw blades series



**54-55**  
硬质合金螺旋铣刀系列  
Carbide spiral cutter series



**56**  
鑽接头/鑽套系列  
Joint drill / drill set series



**57**  
高速钢钻头、钻套系列  
High-speed steel drill bits, drill sleeve series



**58-59**  
各种刀具系列  
Various Tools Series



## 金刚石CNC螺旋铣刀 diamond CNC spiral cutter

产品编号 Product Code	D 刀刃外径 Cutting Diameter	H 刀刃长度 Cutting Length	d 刀柄外径 Outside diameter	L 总长 Total Length	Z 齿数 Teeth Number
D10227011	10	22	12	70	1+1
D12227011	12	25/30	12	70	1+1
D123010011	12	22/26/30	12	100	1+1
D12308011	12.7	26/30/35	12.7	80	1+1
D14309011	14	30	16	90	1+1
D16268011	16	26/30	16	80	1+1
D16309011	16	30/35	16	90	1+1
D16359511	16	35/40	16	95	1+1
D164311511	16	43	16	115	1+1
D18289011	18	28	16/20	90	1+1
D18359511	18	35	16/20	95	1+1
D184311511	18	43	16/20	115	1+1
D20309011	20	30	16/20	90	1+1
D203510011	20	35	16/20	100	1+1
D20389511	20	38	16/20	95	1+1
D204511511	20	45	16/20	115	1+1
D204811011	20	48	16/20	110	1+1
D205012011	20	50	16/20/25	120	1+1
D206012511	20	60	16/20/25	125	1+1

## 2+2金刚石CNC螺旋铣刀 2+2 diamond CNC spiral cutter

产品编号 Product Code	D 刀刃外径 Cutting Diameter	H 刀刃长度 Cutting Length	d 刀柄外径 Outside diameter	L 总长 Total Length	Z 齿数 Teeth Number
D16309522	16	26/30	16/20	95	2+2
D163510022	16	35	16/20	100	2+2
D164311022	16	43	16/20	110	2+2
D18359522	18	35	16/20	95	2+2
D184511522	18	45	20/25	115	2+2
D20309022	20	30	20/25	90	2+2
D203810022	20	38	20/25	100	2+2
D204311022	20	43	20/25	110	2+2
D205012022	20	50/60	20/25	120	2+2
D253811022	25	38	20/25	110	2+2
D254811022	25	48	20/25	110	2+2
D256013022	25	60/72	20/25	130	2+2
D16309522					

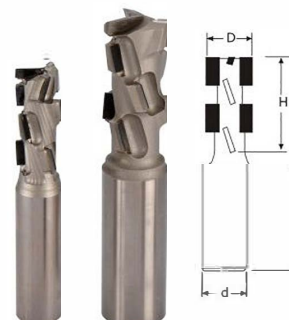

## 金刚石CNC螺旋铣刀 diamond CNC spiral cutter



产品编号 Product Code	D 刀刃外径 Cutting Diameter	H 刀刃长度 Cutting Length	d 刀柄外径 Outside diameter	L 总长 Total Length	齿数 Teeth Number
D20309033	20	30	20/25	90	3+3
D203510033	20	35	20/25	100	3+3
D203811033	20	38	20/25	110	3+3
D204611033	20	46/55	20/25	110	3+3
D252610033	25	26	20/25	100	3+3
D253510533	25	35	20/25	105	3+3
D253811033	25	38	20/25	110	3+3
D254511533	25	45	20/25	115	3+3
D255012533	25	50/55	20/25	125	3+3
D256013533	25	60/72	20/25	135	3+3



## 金刚石直刀 Diamond Straight Knife



产品编号 Product Code	D 刀刃外径 Cutting Diameter	H 刀刃长度 Cutting Length	d 刀柄外径 Outside diameter	L 总长 Total Length	Z 齿数 Teeth Number
D1201	8/10/12	12/15/20	12/12.7/16	60/70/80	1+1
D1202	12.7/14/16	25/30/38	12.7/16/20	70/75/80	1+1
D1203	16/20/22	30/35/38	16/20/25	75/80/90	1+1
D1204	25/28/30	35/38/45	16/20/25	80/90/100	1+1
D1205	16/20/25	48/60/75	16/20/25	85/95/100	1+1

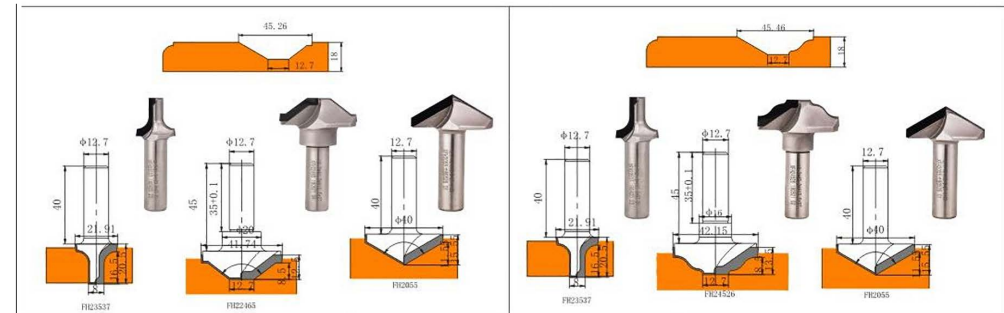

## 金刚石开孔钻头 Diamond opening bit

适用与铰链钻、电话线盒位开孔  
It is suitable for hinged drill and telephone line box opening



产品编号 Product Code	D 刀刃外径 Cutting Diameter	H 刀刃长度 Cutting Length	d 刀柄外径 Outside diameter	L 总长 Total Length	Z 齿数 Teeth Number
D1206	30/35/40	4.5/5/6	12/12.7/15	70/75/80	2+2
D1207	45/60/80	4.5/5.5/6	12/15/16	70/80/90	2+2

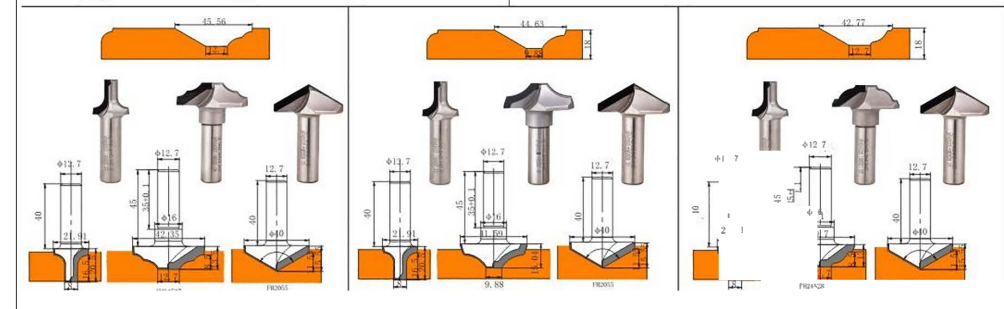

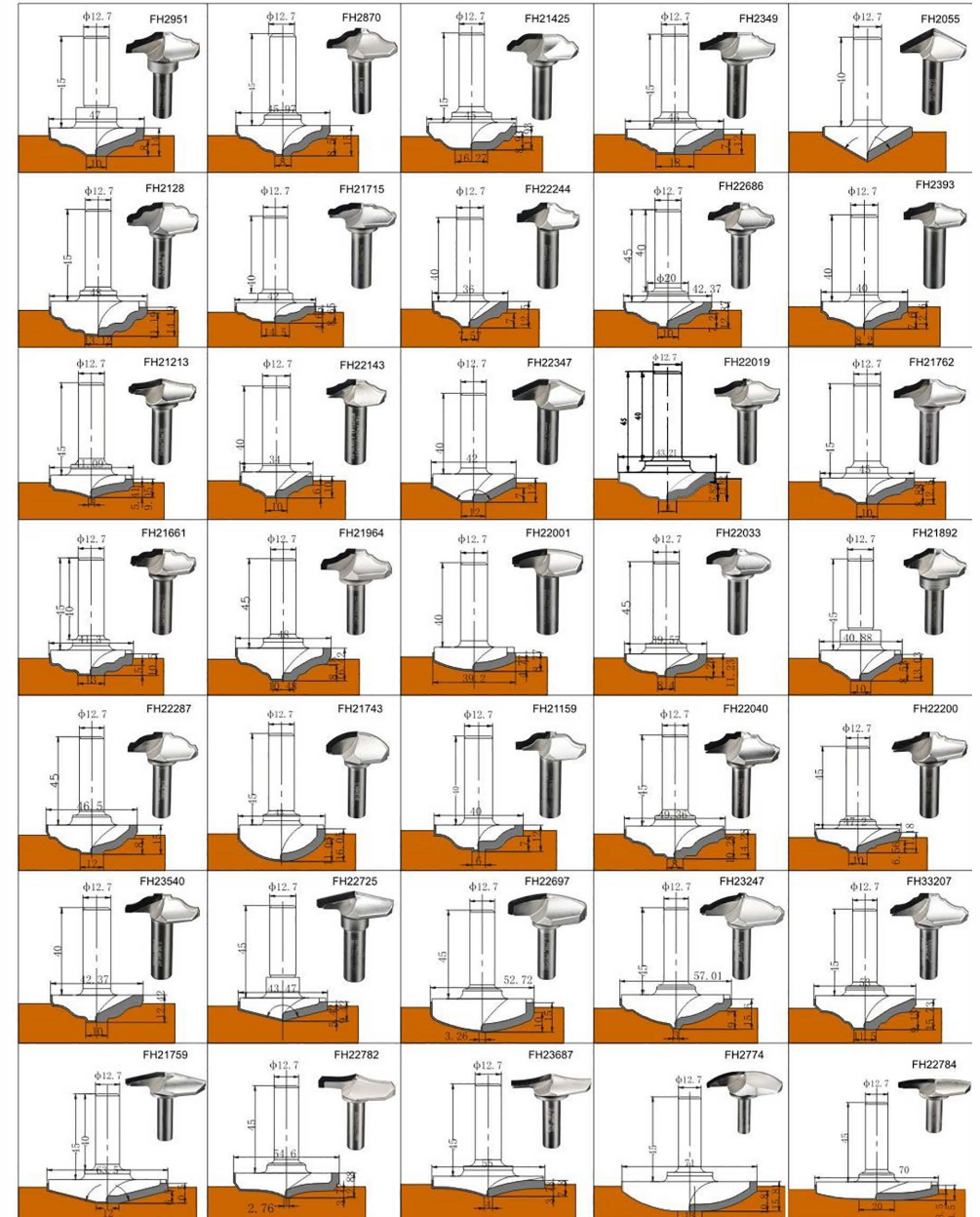
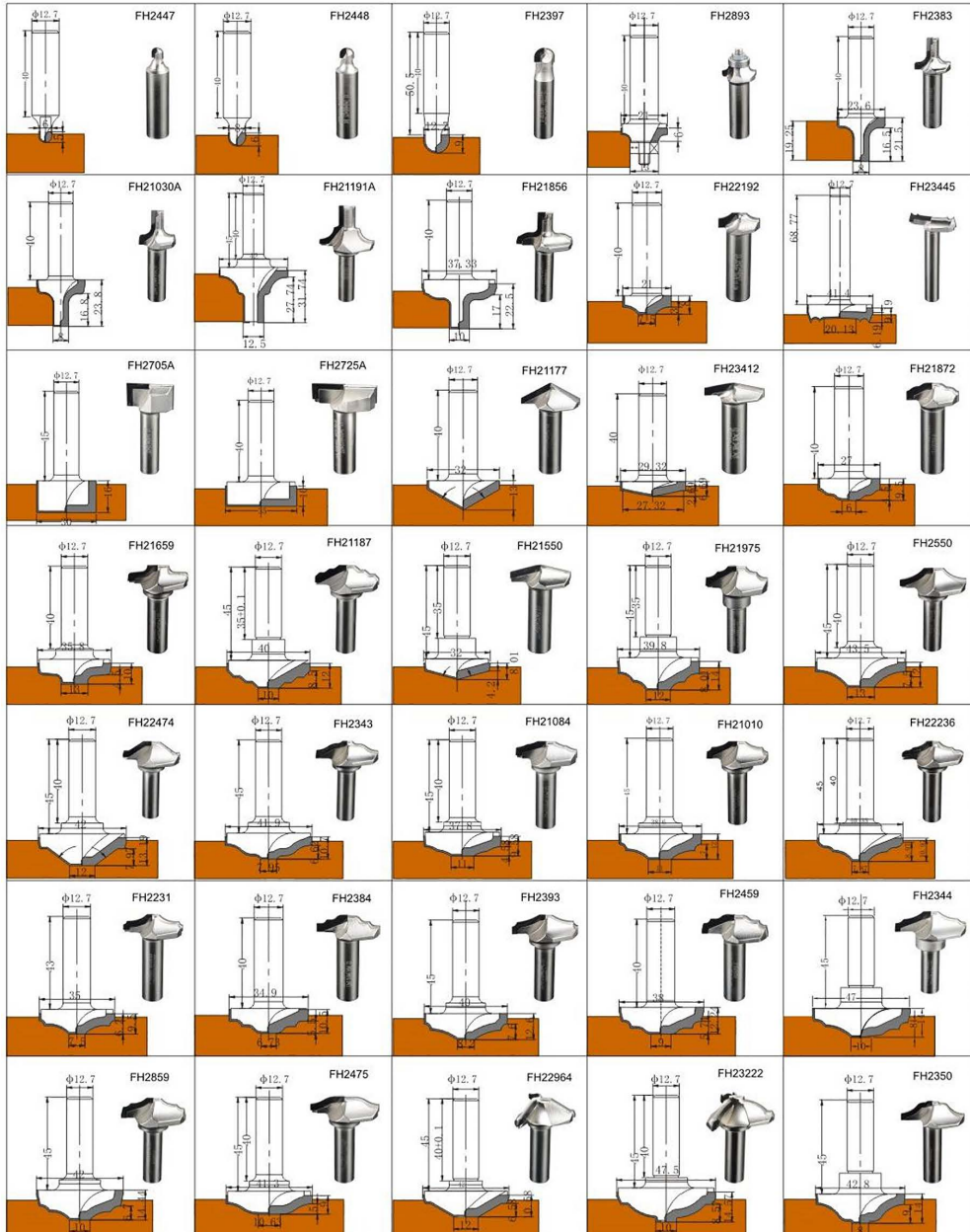

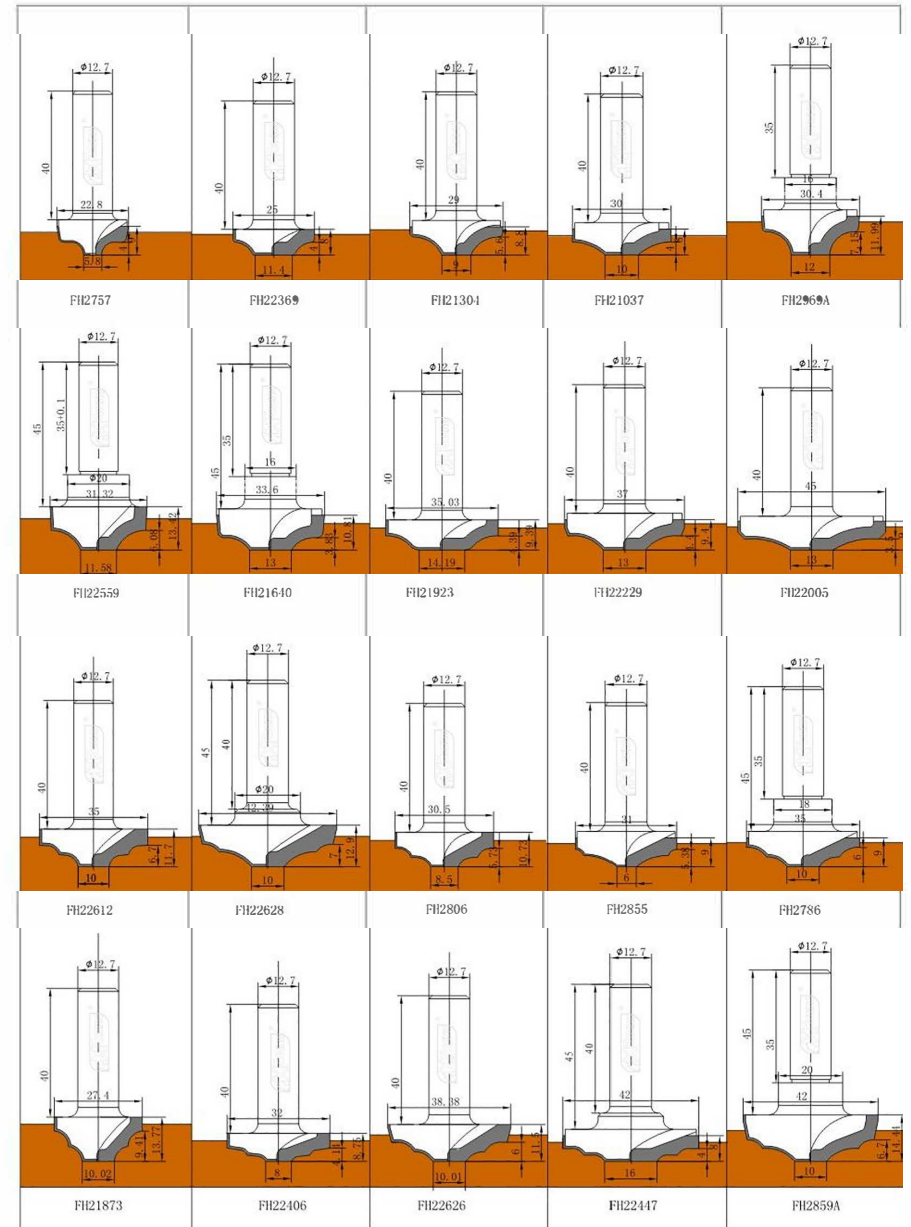
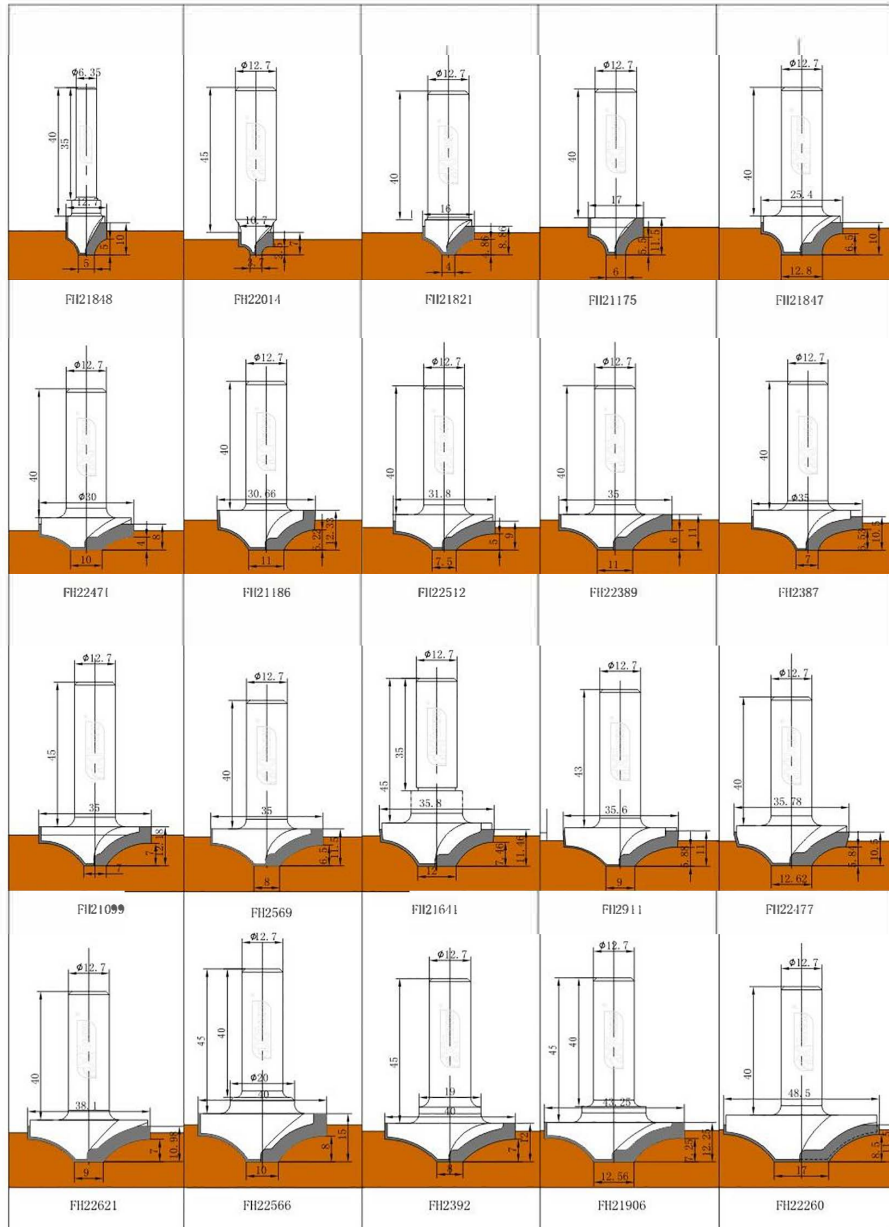

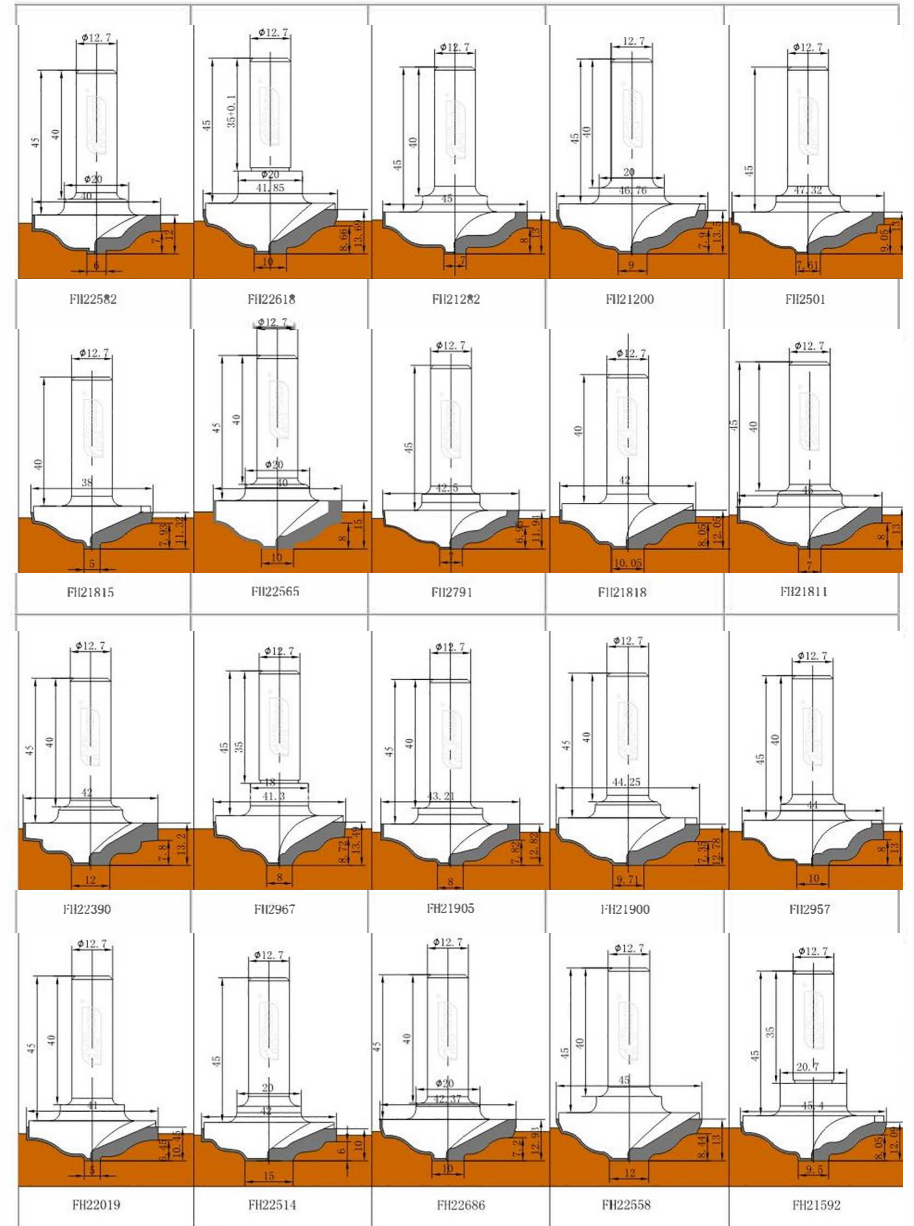
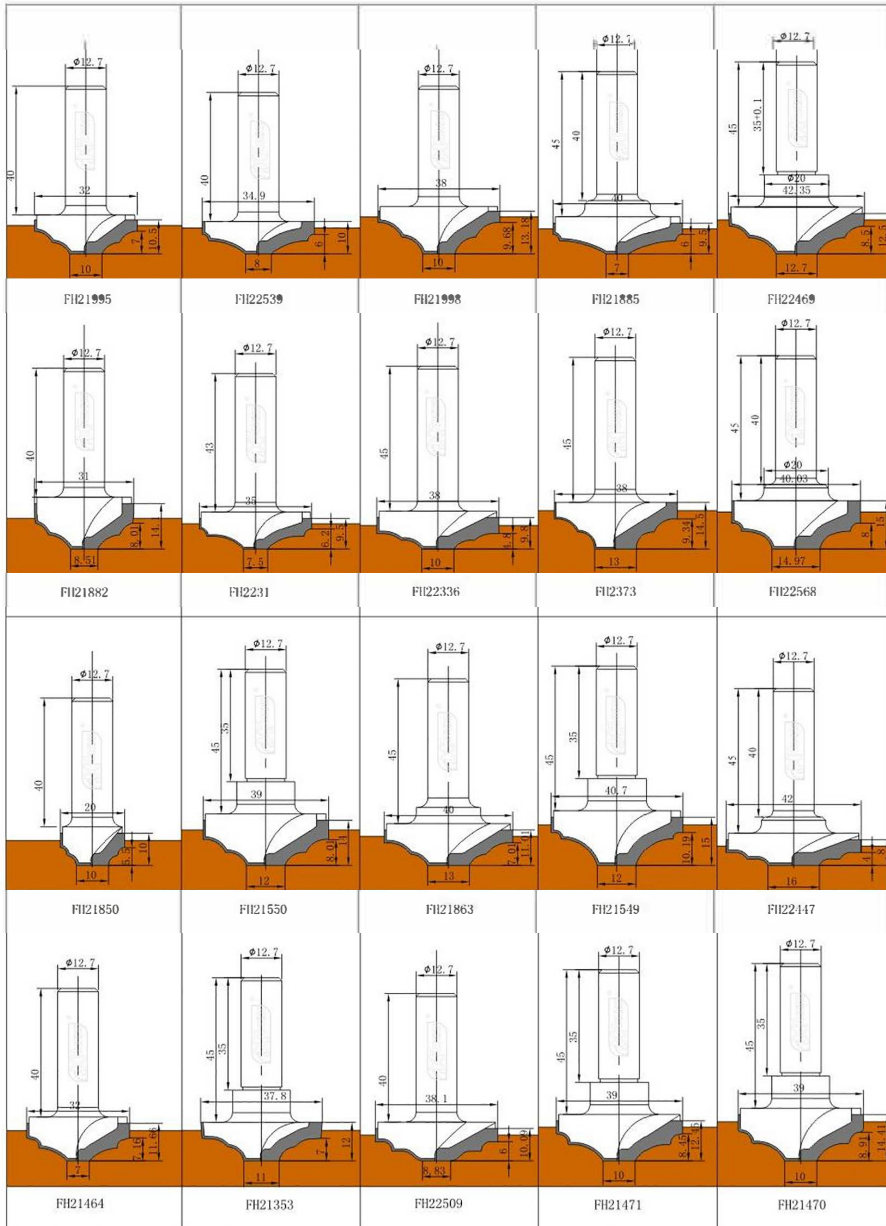

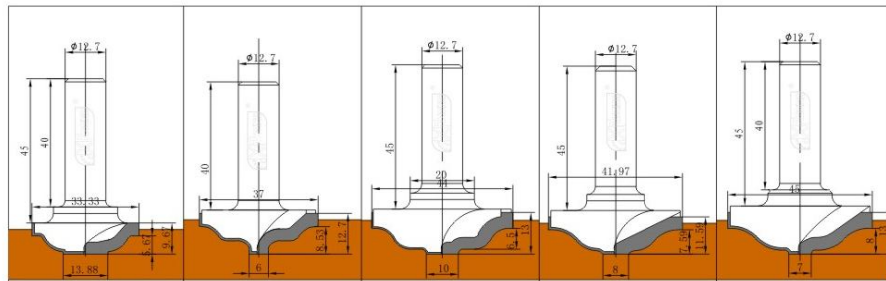

FH21901 FH22003 FH2957A FH21833 FH22428

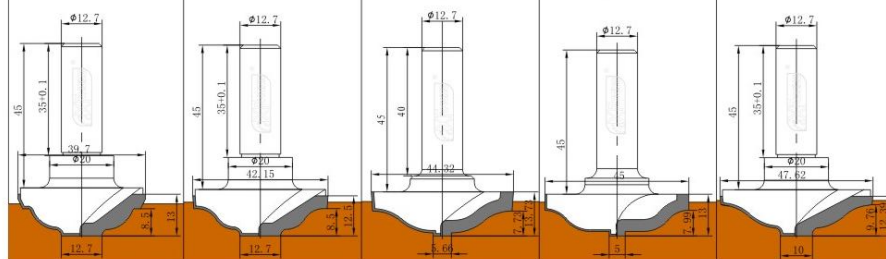

FH22467 FH22470 FH22488 FH2612 FH22492

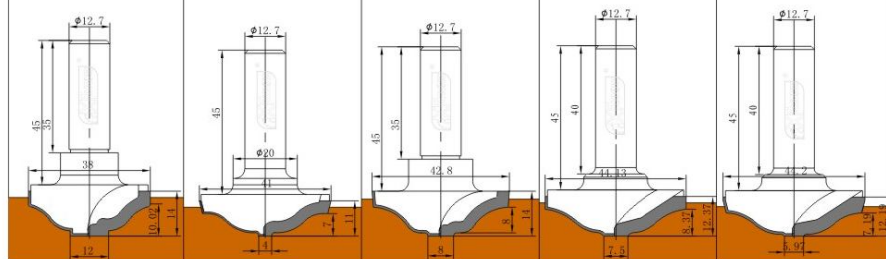

FH21548 FH2358 FH2350 FH22279 FH22299

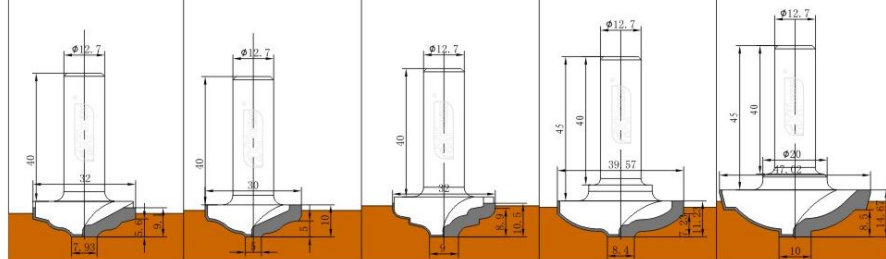

FH21948 FH21950 FH2510 FH22033 FH22624

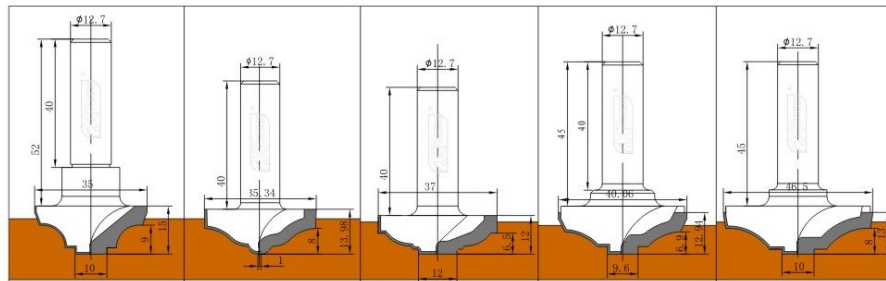

FH2805 FH21185 FH22294 FH21916 FH2881

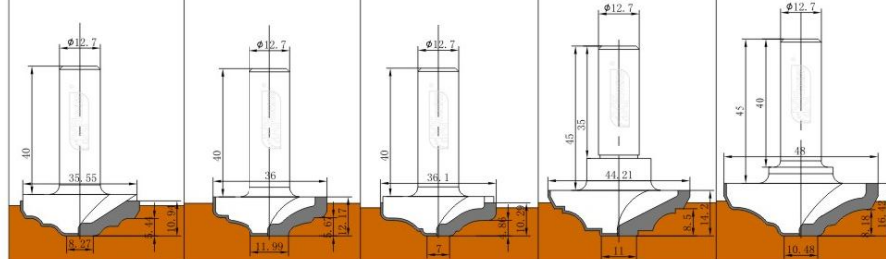

FH22252 FH22042 FH21999 FH21812 FH21964

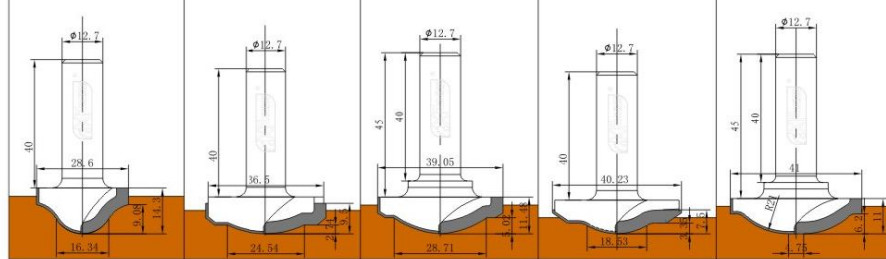

FH22241 FH22231 FH21870 FH22478 FH21945

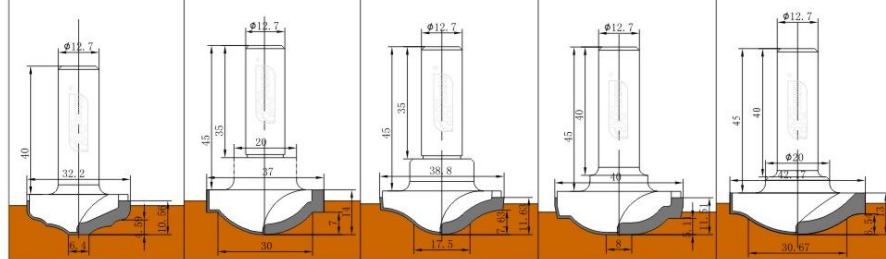

FH21849 FH2192 FH21473 FH21463 FH22586

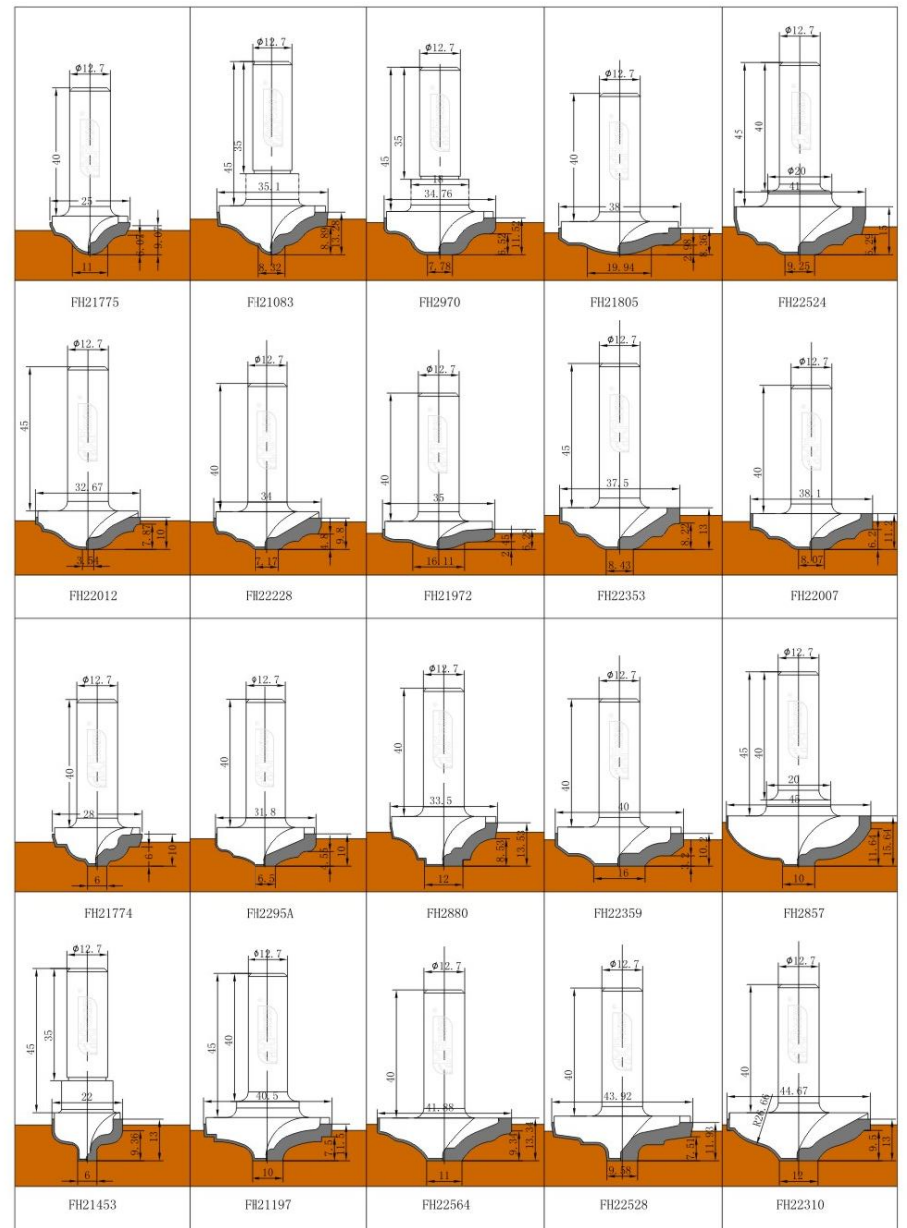
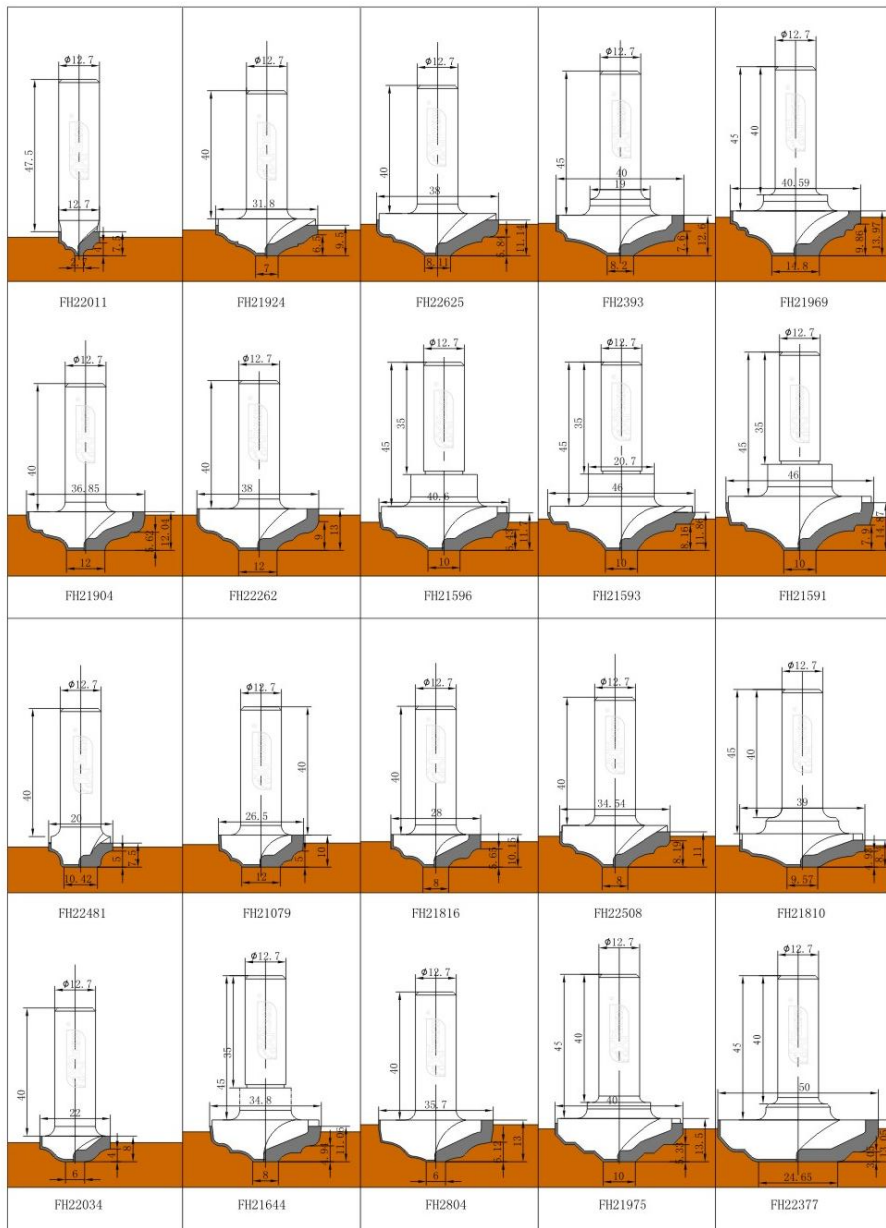

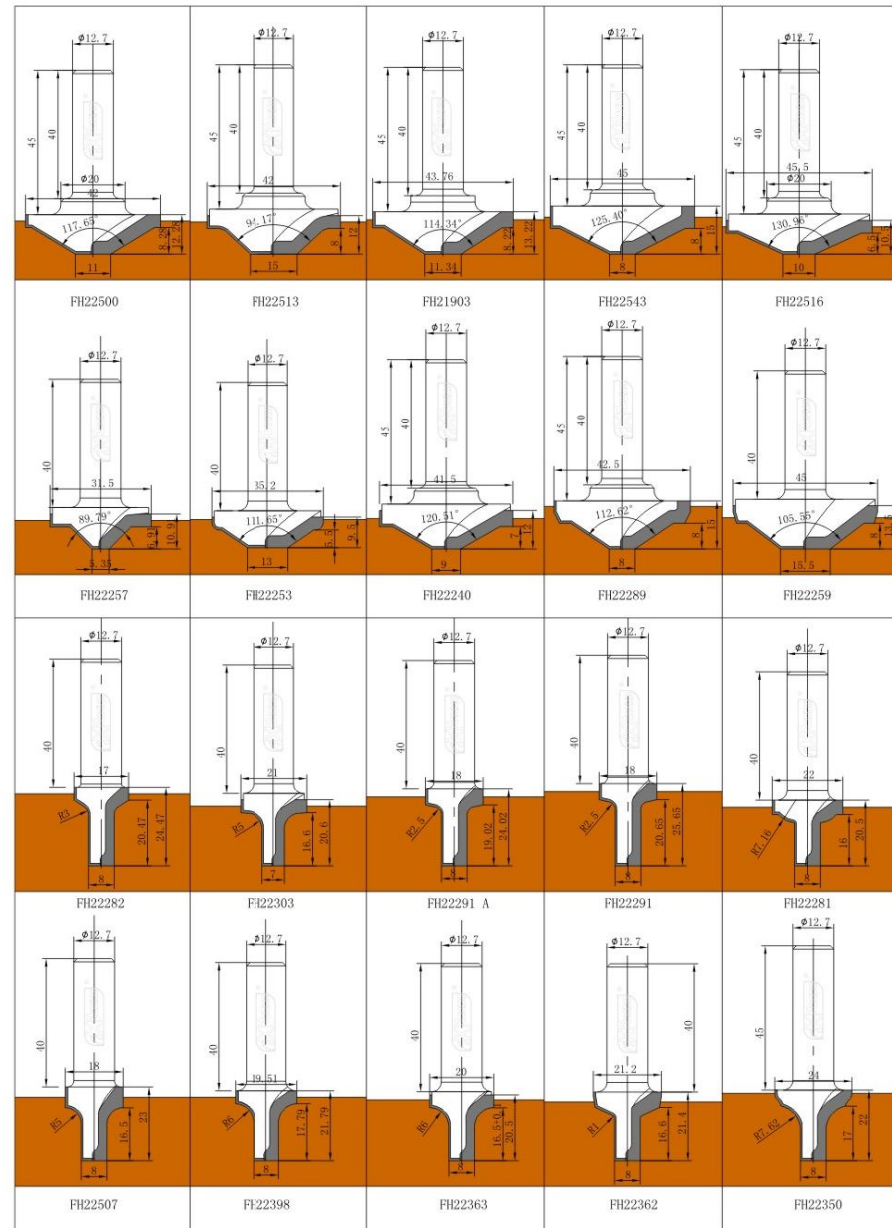
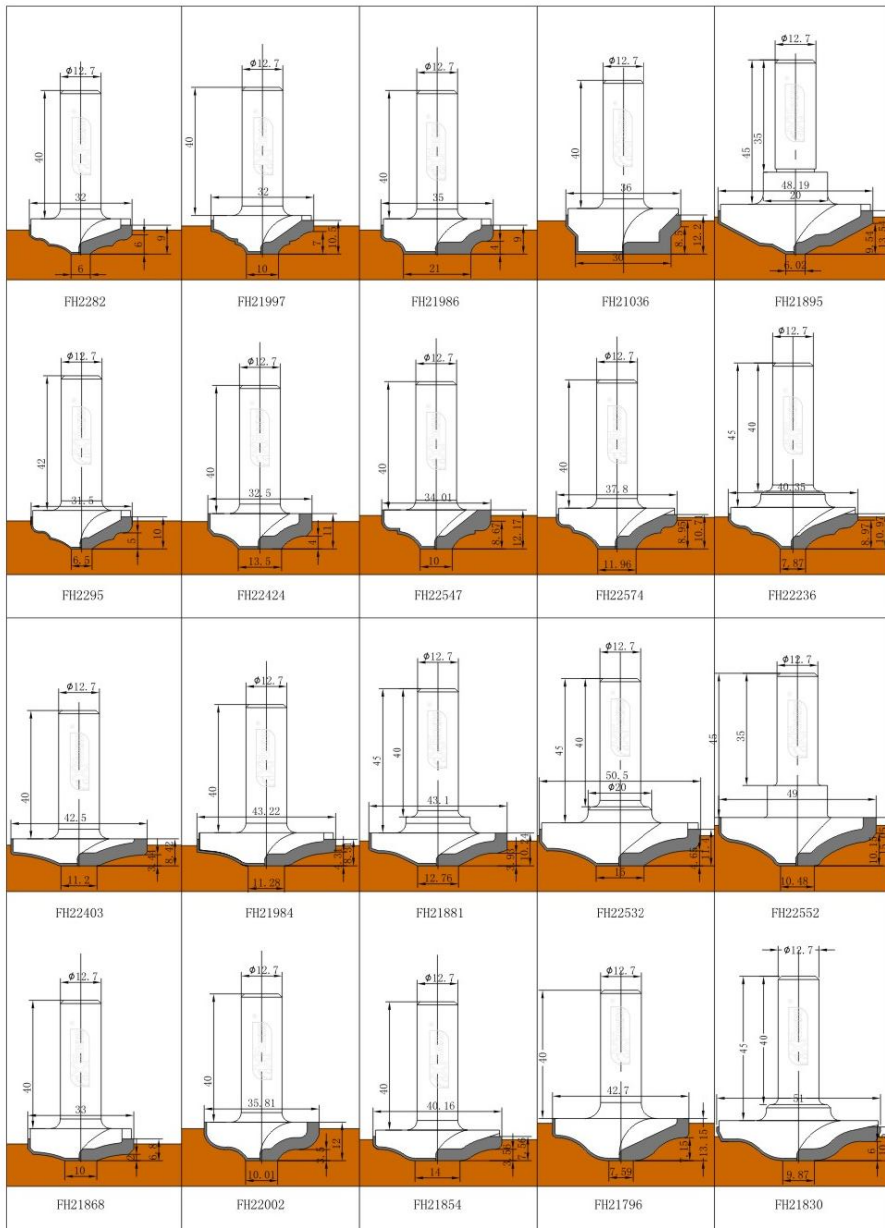

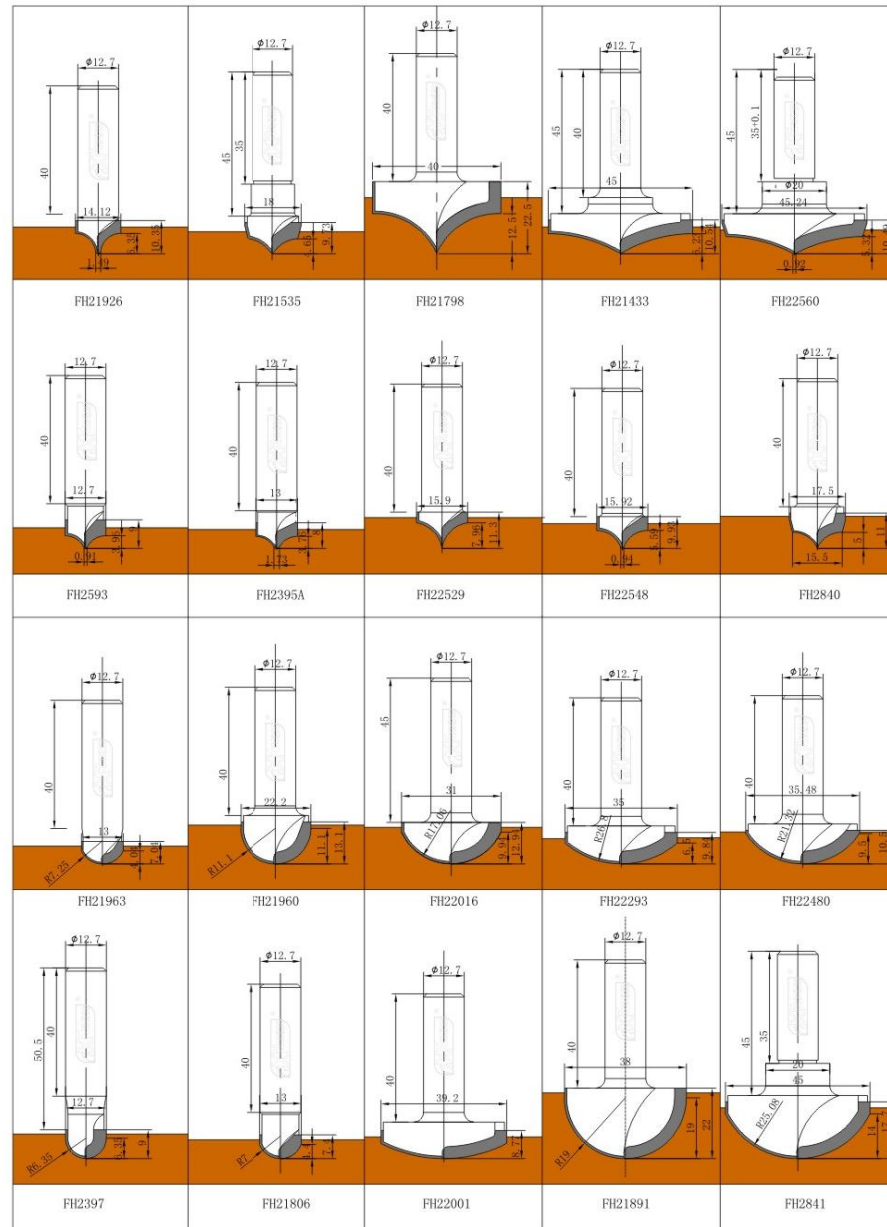
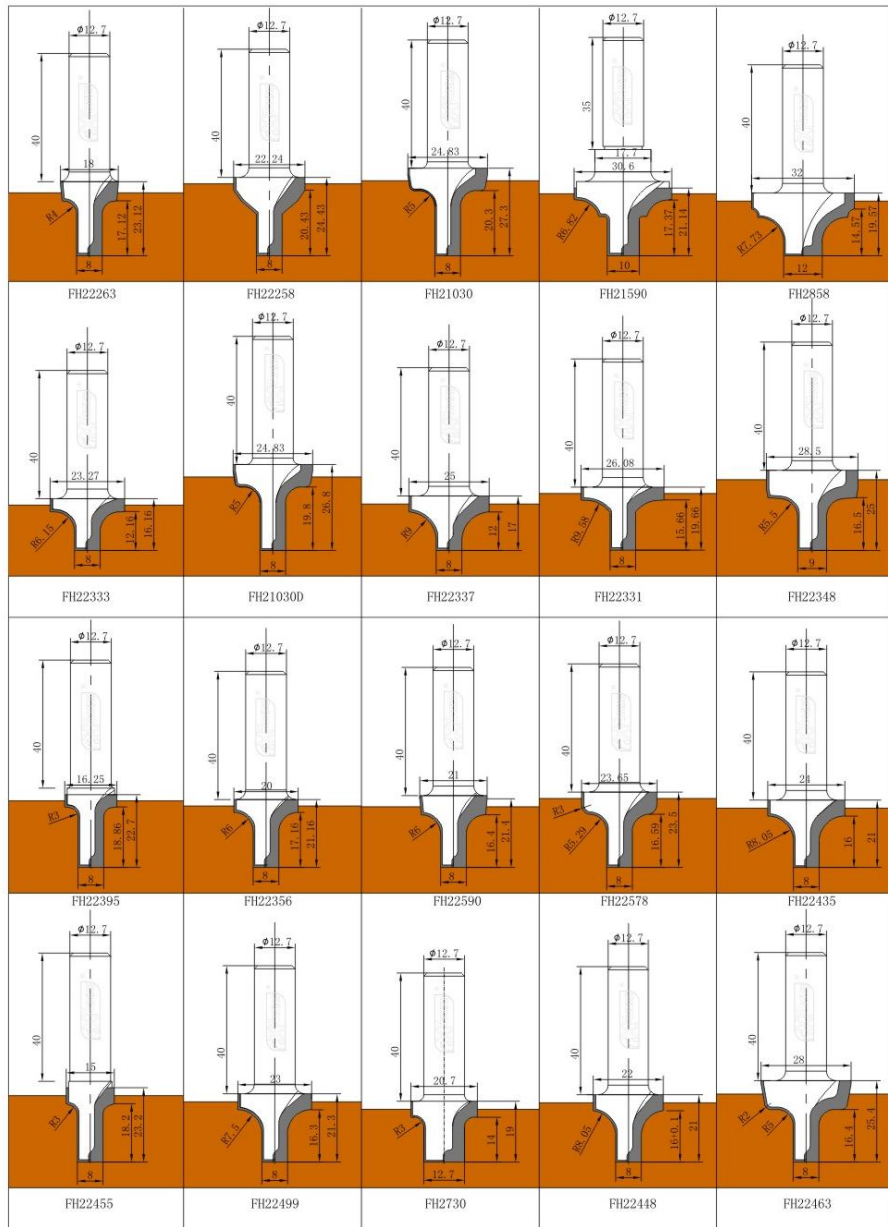

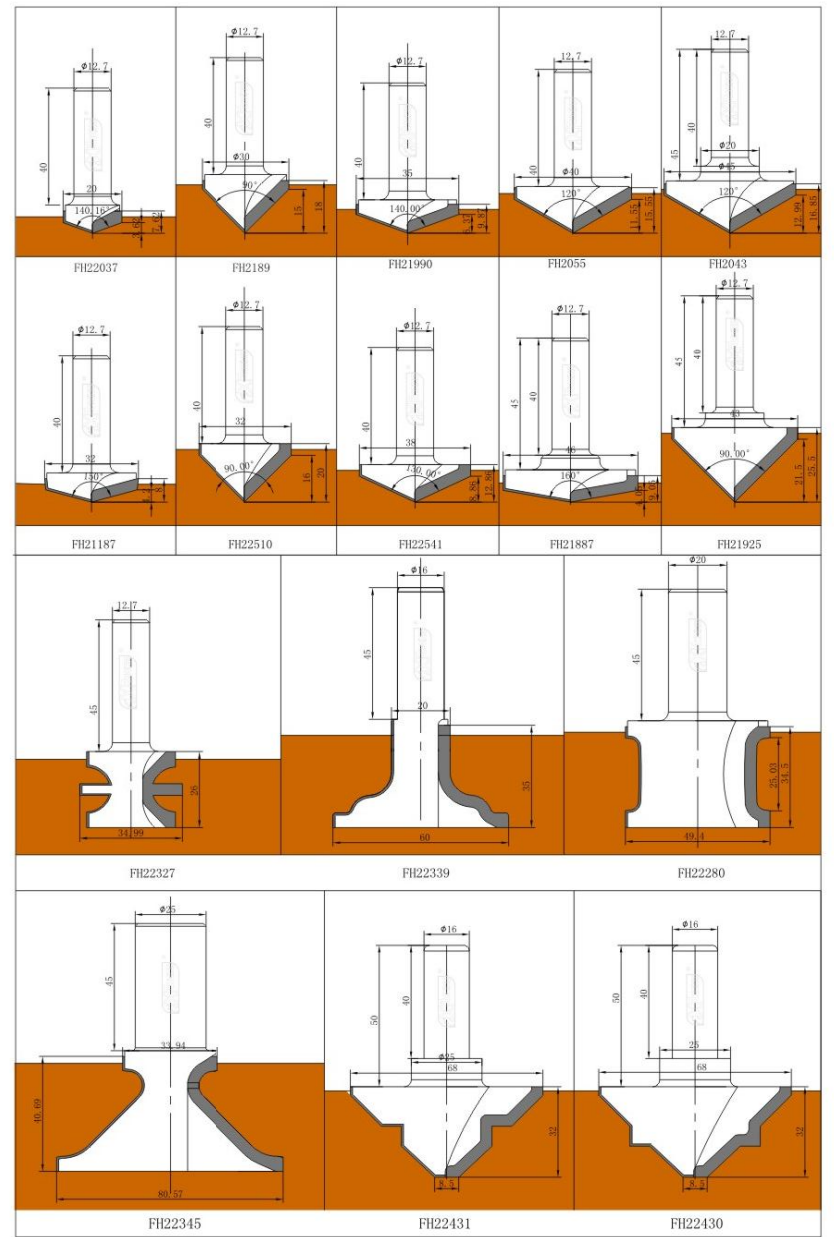
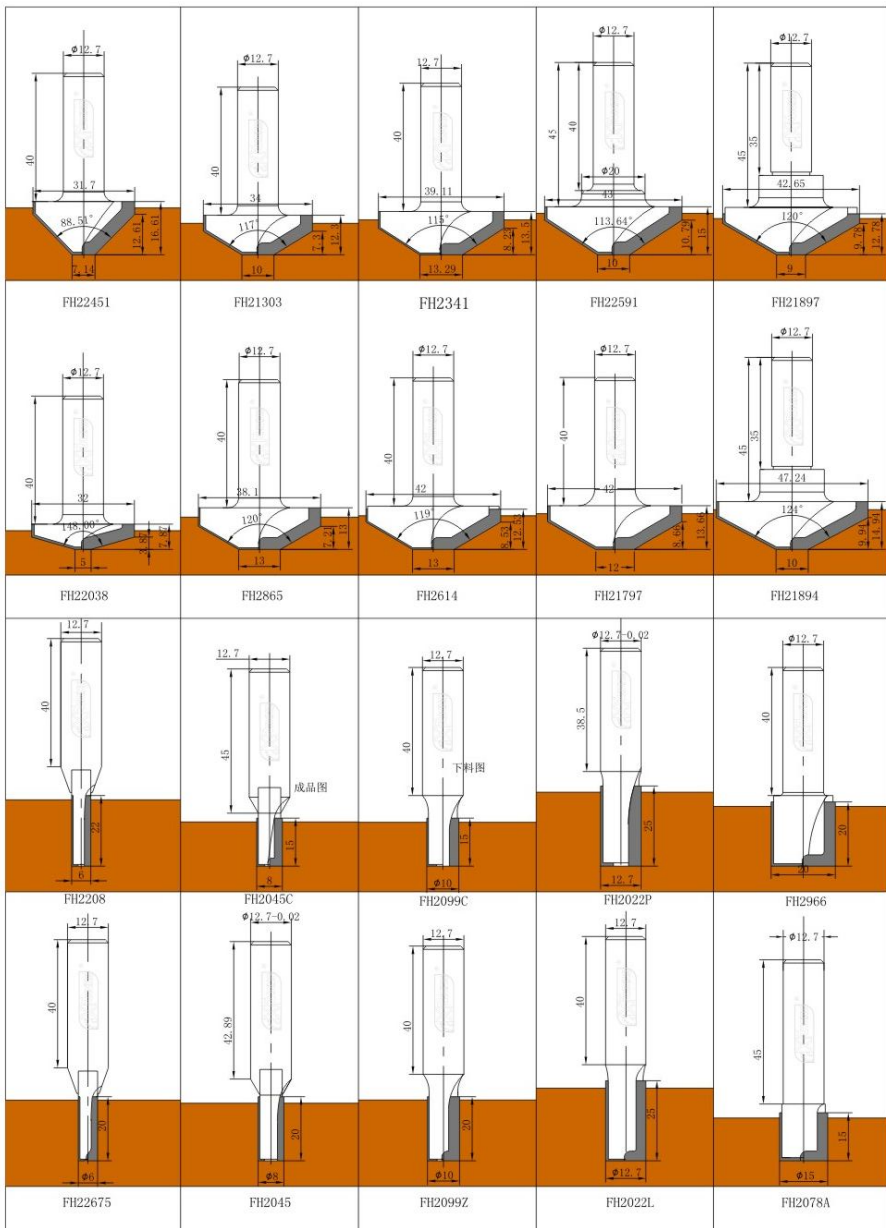



## 特殊订制金刚石刀具系列

Special custom-made diamond knives series

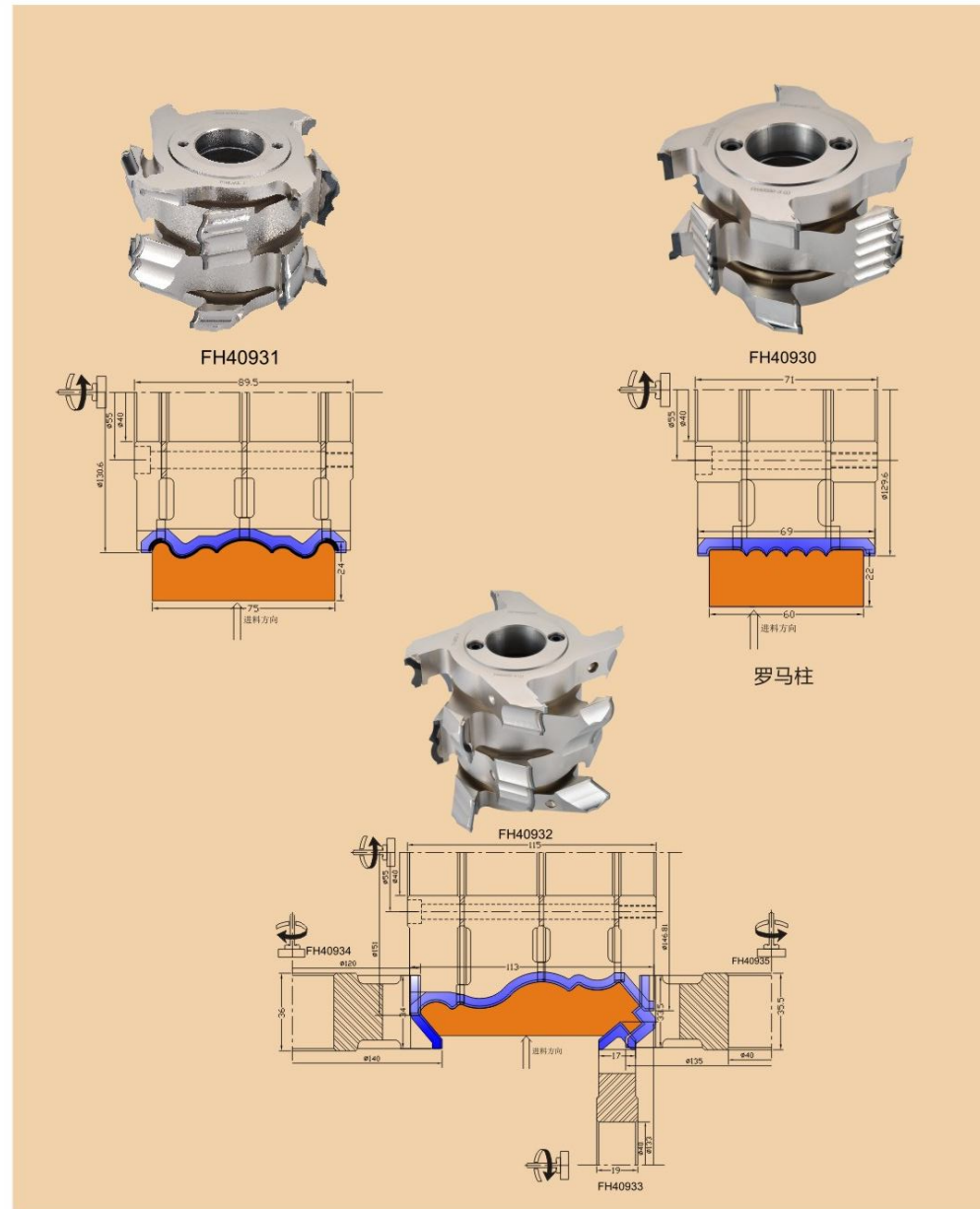





F602A

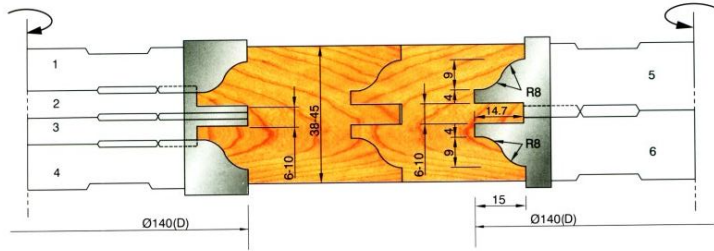

F602B

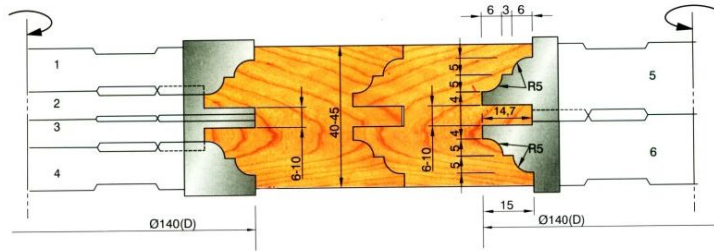

F602C

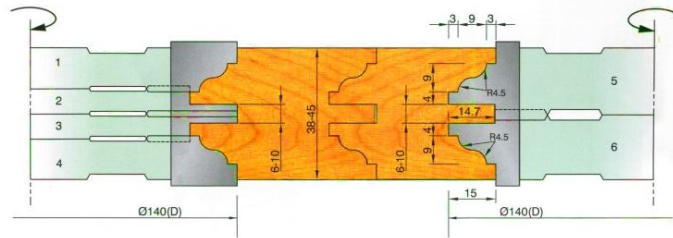

F602D

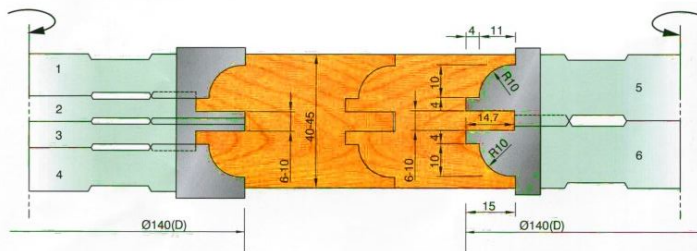

F603A

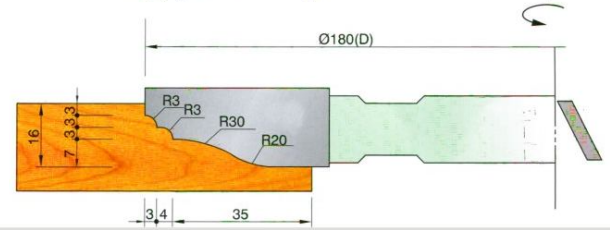
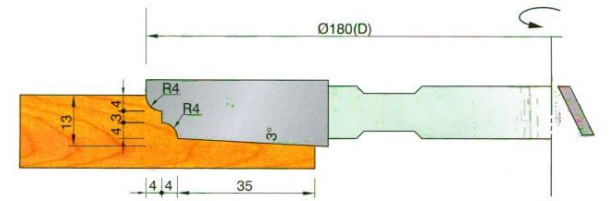

F603B

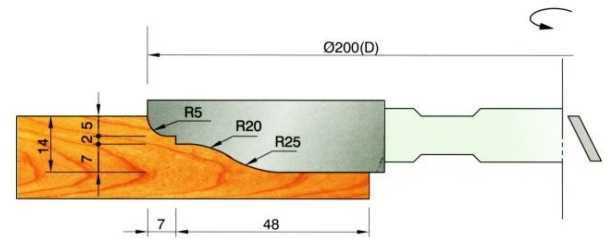

F603C

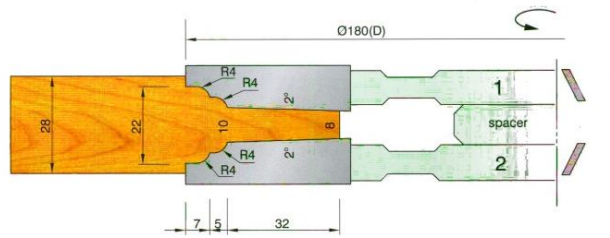

F603D

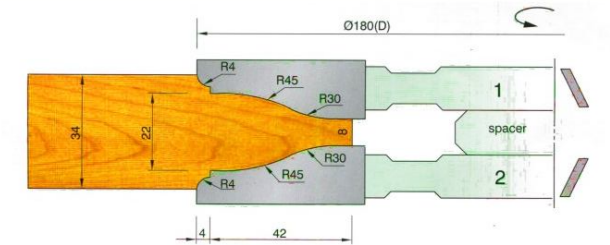



**金刚石封边机预铣刀**  
Diamond edge banding machine pre-cutter

产品编号 Product Code	D 刀刃外径 Cutting Diameter	H 刀刃高度 Blade height	d 孔径 Aperture	Z 齿数 Teeth Number
D8001	80	35	20/25.4	3+3
D8002	80	35	20/30	3+3
D8003	80	50	20	3+3
D8004	80	65	20	3+3

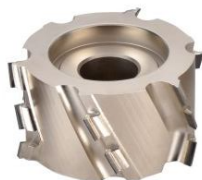

**金刚石封边机预铣刀**  
Diamond edge banding machine pre-cutter

产品编号 Product Code	D 刀刃外径 Cutting Diameter	H 刀刃高度 Blade height	d 孔径 Aperture	Z 齿数 Teeth Number
D1001	100	35	30	3+3
D1002	100	43	30	3+3
D1003	100	48	30	3+3
D1004	100	50	30	3+3
D1005	100	55	30	3+3/6+6
D1006	100	63	30	3+3



**金刚石封边机预铣刀**  
Diamond edge banding machine pre-cutter

产品编号 Product Code	D 刀刃外径 Cutting Diameter	H 刀刃高度 Blade height	d 孔径 Aperture	Z 齿数 Teeth Number
D12501	125	35	30	3+3/4+4
D12502	125	43	30	3+3/6+6
D12503	125	48	30	3+3
D12504	125	63	30	3+3
D12505	125	84	30	3+3
D12506	125	106	30	3+3
D12001	125	35	30	3+3/4+4
D12002	120	43	30	3+3/6+6
D12003	120	48	30	3+3
D12004	120	63	30	3+3
D12005	120	84	30	3+3
D12006	120	106	30	3+3



**金刚石封边机预铣刀**  
Diamond edge banding machine pre-cutter

产品编号 Product Code	D 刀刃外径 Cutting Diameter	H 刀刃高度 Blade height	d 孔径 Aperture	Z 齿数 Teeth Number
D12505	125	63	25.4/30	3+3
D12506	125	63/84	30	3+3/6+6
D12507	125	106	30	3+3



**金刚石封边机预铣刀**  
Diamond edge banding machine pre-cutter

产品编号 Product Code	D 刀刃外径 Cutting Diameter	H 刀刃高度 Blade height	d 孔径 Aperture	Z 齿数 Teeth Number
D15001	150	35	30	4+4/6+6
D15002	150	43	30	3+3/4+4
D15003	150	46	30	4+4
D15004	150	55	30	4+4
D15005	150	65	30	4+4
D15006	150	84	30	6+6
D15007	150	85	30	3+3



**金刚石封边机预铣刀**  
Diamond edge banding machine pre-cutter

产品编号 Product Code	D 刀刃外径 Cutting Diameter	H 刀刃高度 Blade height	d 孔径 Aperture	Z 齿数 Teeth Number
D12501A	125	85/106	30	3+3
D16001	160	65	30	4+4
D18001	180	65	30	4+4
D18002	180	65	30	6+6
D20001	200	20	30	6+6
D20002	200	30	30	8+8
D20004	200	40	30	10+10

## 金刚石粗修刀 Diamond finishing knife

产品编号 Product Code	D 刀刃外径 Cutting Diameter	H 刀刃高度 Blade height	d 孔径 Aperture	Z 齿数 Teeth Number
D5012164	50	12	16	4
D5614164	56	14	16/20	4
D6112164	61	12	16	4
D7020164	70	20	16/20	4
D8020206	80	20	20	4/6

A型用于Brandt、Homa、IDM、IMA、KDT  
封边机上,对实木、平板和塑料封边条的粗修和倒角。  
B型用于Brandt、Homa、IDM、IMA、KDT  
封边机上,对实木、平板和塑料封边条的粗修和倒角。

## 金刚石精修刀 Diamond finishing knife

产品编号 Product Code	D 刀刃外径 Cutting Diameter	H 刀刃高度 Blade height	D 孔径 Aperture	Z 齿数 Teeth Number	R 弧度 Radian
D5001	50	12	20/22	4/6	2/3
D6901	69	13	16/20	4/6	1.5/2/3

## 金刚石精修刀 Diamond finishing knife

产品编号 Product Code	D 刀刃外径 Cutting Diameter	H 刀刃高度 Blade height	D 孔径 Aperture	Z 齿数 Teeth Number	R 弧度 Radian
D7501	75	16	20/22	4/6	1.5/2/3

特点: 刃口强度高, 尺寸精确耐用, 锋利性好, 是合金刀具30~50倍  
寿命  
适用: 华力、极东KDT、豪德、南兴机械上使用。

## 金刚石封边机跟踪刀/修边刀 Diamond knife edge banding machine tracking

产品编号 Product Code	D1 刀刃外径1 Cutting Diameter1	D2 刀刃外径1 Cutting Diameter1	d 孔径 Aperture	Z 齿数 Teeth Number	R 弧度 Radian
D73623241	73	62	HSK32	4	1/2
D746232415	74	62	HSK32	4	12-15/2
D75623242	75	62	HSK32	4	2
D75623262	75	62	HSK32	6	2
D79662562	79	66	HSK25	6	
D847025415	84	70	HSK25	4	15/2
D847025615	84	70	HSK25	6	15/2
D847032415	84	70	HSK32	4	15/2
D84703262	84	70	HSK32	6	15/2/3

## 金刚石铣刀 Diamond Milling

产品编号 Product Code	D 刀刃外径 Cutting Diameter	H 刀刃长度 Cutting Length	d 刀柄外径 Outside diameter	L 总长 Total Length	Z 齿数 Teeth Number
D151517021	15	15	16/20	170/200	2+1
D181517021	18	15	16/20	170/200	2+1
D201517021	20/22	15	20/25	170/200	2+1
D251717021	25/28	17	20/25	170/200	2+1
D301720021	30/32	17	20/25	170/200	2+1

## 金刚石平面铣刀 Diamond plane cutter

产品编号 Product Code	D 刀刃外径 Cutting Diameter	H 刀刃长度 Cutting Length	d 刀柄外径 Outside diameter	L 总长 Total Length	Z 齿数 Teeth Number
D206704	26/50/75	6/12	20/25	70	2/4/6
D206804	36/60/80	6/12	20/25	80	2/4/6
D256804	40/70/80	6/12	20/25	80	2/4/6



## 金刚石地板成型刀 Diamond Panel Molding Cutting Tool

产品编号 Product Code	D 外径 Cutting Diameter	d 孔径 Aperture	Z 齿数 Teeth Number	H 把/套 Sets
D130304044	Φ130	Φ30 Φ40	4/6	4/6/8
D140304044	Φ140	Φ30 Φ40	4/6	4/6/8
D160304046	Φ160/Φ175	Φ25.4 Φ30 Φ40	4/6	6/8/10

## 金刚石地板预切刀 Diamond Panel Molding Cutting Tool

产品编号 Product Code	D 外径 Cutting Diameter	d 孔径 Aperture	Z 齿数 Teeth Number	H 把/套 Sets
D130304044	Φ130	Φ30 Φ40 Φ60	8/10/12	1/2
D140304044	Φ140	Φ30 Φ40 Φ60	10/12/16	1/2
D160304044	Φ160/Φ220/Φ250	Φ30 Φ40 Φ60	12/16/24/36	1/2

## 金刚石地板精修刀 Diamond Panel Rabbeting Cutting

产品编号 Product Code	D 外径 Cutting Diameter	d 孔径 Aperture	Z 齿数 Teeth Number	B 齿高 Tooth height
D16040127	Φ160	Φ40	12	7
D160401245	Φ160	Φ40	12	4.5
D22060367	Φ220	Φ60	18/24/36	7
D220603645	Φ220	Φ60	18/24/36	4.5
D25060367	Φ250	Φ60	18/24/36	7
D250603645	Φ250	Φ60	24/36/42	4.5
D285603610	Φ285	Φ60	24/36/48	10

## 金刚石粉碎刀 Diamond crushing blade

产品编号 Product Code	D 外径 Cutting Diameter	d 孔径 Aperture	Z 齿数 Teeth Number	B 齿高 Tooth height
D25001	250	60/80	33/36/48	6.5/10
D25002	250	60/80	24(20+4)	10/23
D25003	250	60/80	36(30+6)	10/23
D25004	250	60/80	42(35+7)	10/23
D25005	250	60/80	48(40+8)	10/23
D25006	250	60/80	54(45+9)	10/23
D25007	250	60/80	60(50+10)	14.5/23
D25008	250	60/80	63(42+21)	14.5/23

## 硬质合金粉碎刀 Carbide crushing blade

产品编号 Product Code	D 外径 Cutting Diameter	d 孔径 Aperture	Z 齿数 Teeth Number	B 齿高 Tooth height
D2001	Φ200	Φ35/40/80	24	6
D2002	Φ200	Φ35/40/80	36	6
D2003	Φ200	Φ35/40/80	48	6
D2504	Φ250	Φ35/40/80	24	6
D2505	Φ250	Φ35/40/80	36	6
D2506	Φ250	Φ35/40/80	48	6
D2507	Φ250	Φ35/40/80	54/60	6

## 硬质合金粉碎刀/双端铣粉碎锯 Carbide crushing blade/Double-end milling grinding saws

产品编号 Product Code	D 外径 Cutting Diameter	d 孔径 Aperture	Z 齿数 Teeth Number	B 齿高 Tooth height
D2008	Φ200	Φ35/40/50	36/42	4
D2009	Φ200	Φ35/40/80	48-4	4
D2010	Φ200	Φ35/40/80	52-4	4.2
D2511	Φ250	Φ35/40/80	52-4	4.2
D2512	Φ250	Φ35/40/80	60-6	4.2
D2513	Φ255	Φ35/40/80	60-6	4.5
D3014	Φ300	Φ35/40/130	72-2	4.5
D3515	Φ350	Φ35/40/80	72-2	4.5
D3516	Φ350	Φ35/40/80	84	4.5

## 硬质合金组合粉碎刀(梳棒机和双端铣机用) Carbide combination smash knife

产品编号 Product Code	D 外径 Cutting Diameter	d 孔径 Aperture	Z 齿数 Teeth Number	B 齿高 Tooth height
D2017	Φ200	Φ35/40/80	24/36	4
D2018	Φ200	Φ35/40/80	32/42	4
D2019	Φ200	Φ35/40/80	36/48	4.2
D2520	Φ250	Φ35/40/80	48/60	4.2
D2521	Φ250	Φ35/40/80	48/60	4.2
D2522	Φ255	Φ35/40/80	48/60	4.5
D3023	Φ300	Φ35/40/80	60/72	4.5
D3524	Φ350	Φ35/40/80	60/72	4.5
D3525	Φ350	Φ35/40/80	72/80/84	4.5



### 轻切削舍弃式螺旋刀头 Sprial Cutterhead

产品编号 Product Code	D 刀刃外 Cutting Diameter	d 孔径 Aperture	H 高度 Height	Z 齿数 Teeth Number
F1000	100	35	80	6
F1001	100	35	100	6
F1002	100	35	130	6
F1003	100	35	150	6
F1004	125	40	80	6
F1005	125	40	100	6
F1006	125	40	130	6
F1007	125	40	150	6

配件 Parts : TCT刀片 : (1)14\*14\*2 (2)15\*15\*2.5\*35° (3)15\*15\*2.5\*37°

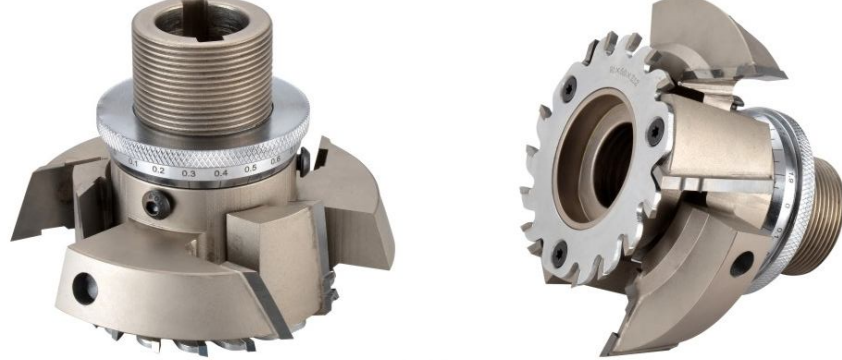

F701



### 重切削舍弃式螺旋刀头 Heavy Duty Sprial Cutterhead

产品编号 Product Code	D 刀刃外 Cutting Diameter	d 孔径 Aperture	H 高度 Height	Z 齿数 Teeth Number
F1008	90	30/35	80/100/120	6/8
F1009	100	30/35	80/100/120	6/8
F1010	125	35/40	80	6/8
F1011	125	35/40	100	6/8
F1012	125	35/40	130	6/8
F1013	125	35/40	150	6
F1014	125	40/50.8	180	6
F1015	125	40/50.8	200	6
F1016	125	40/50.8	230	6
F1017	125	40/50.8	250	6
F1018	125	40/50.8	300	6

配件 Parts : TCT刀片 : (1)14\*14\*2\*35° (2)15\*15\*2.5\*35°/37° (3)30\*1.5\*35°

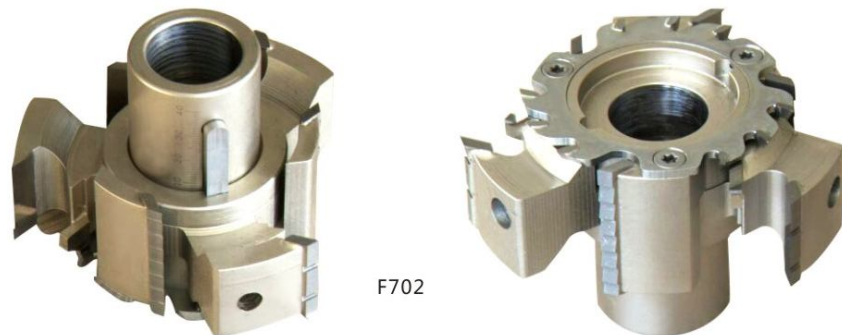

F702



### 焊接式螺旋平刀 Sprial Cutterhead

产品编号 Product Code	D 刀刃外 Cutting Diameter	d 孔径 Aperture	H 高度 Height	Z 齿数 Teeth Number
F1019	100	30/35	80	6/8
F1020	125	40	100	6/8
F1021	125	40	125	6/8
F1022	125	40/50.8	150	6/8
F1023	125	40/50.8	180	6/8
F1024	125	40/50.8	200	6/8



FH30858A

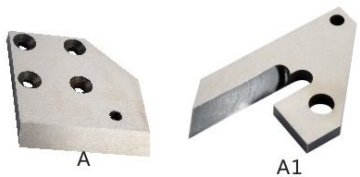

**A 封边机下刀片(正/反刀)**  
Edge-banding Machine Blade  
(Upside&Downside)  
适用于WelleX,Nanxing,Guanglong  
Models  
规格:100x100x10  
Spec:110x110x10  
材料1: 镶高速钢 材料2: 全钢  
Materials1.High-speed Steel  
Materials2.Steel

**A1封边机上刀片(正/反刀)**  
Edge-banding Machine Blade  
(Upside&Downside Blade)  
适用于WelleX,Nanxing,Guanglong  
Models  
规格:125x70x9.6  
Spec:125x70x9.6  
材料1: 镶高速钢 材料2: 全钢  
Materials1.High-speed Steel  
Materials2.Steel



**B 封边机剪切刀**  
Edge-banding machine cutter  
适用于Jidong KDT Models  
规格:100x82x7  
Spec:100x82x7  
材料1: 镶高速钢 材料2: 全钢  
Materials1.High-speed Steel  
Materials2.Steel

**B1刀柱**  
Jidong Models  
适用于Jidong KDT Models  
规格:110x22x13.5  
Spec:110x22x13.5  
材料: 全钢  
Materials:Steel

### 封边条两端修边锯片 Edge trimming blade at both ends

产品编号 Product Code	D 外径 Cutting Diameter	B 刀厚 Blade thickness	d 孔径 Aperture	Z 齿数 Teeth Number
T9201	Φ92	3.0	22/32	8/16
T1001	Φ92	3.2	22/32	30
T1002	Φ92	4.0	22/32	24
T1003	Φ100	2.6	32	20/30
T1004	Φ100	3.0	32	20/24
T1005	Φ100	3.2	22/32	20/24
T1006	Φ100	3.2	32	30
T1041	Φ100	3.5	20	20
T1101	Φ100	3.5	22	20/24
T1201	Φ104	3.0	22	30
T1251	Φ110	3.0	20/22/40	30
T1252	Φ120	3.2	40	20
T1501	Φ125	3.0/3.6	20/40	24/30
T1502	Φ125	3.5	25.4	36
T1503	Φ150	2.8	20	30
T1504	Φ150	3.5	25.4	36
T1801	Φ150	3.0	20	36
T1701	Φ160	3.2	22	36
T170	Φ180	3.2	30	58
T	Φ170	3.5	30	48

### 可换刀片式预铣刀 Interchangeable blade pre-cutter

产品编号 Product Code	D 刀刃外径 Cutting Diameter	H 刀刃高度 Cutting Height	d 孔径 Aperture	z 齿数 Teeth Number
F1025	80	50	20	3+3
F1026	80	60	20	3+3
F1027	80	65	30	3+3
F1028	100	56	30	3+3
F1029	120	65	30	3+3
F1030	125	60	30	3+3
F1031	150	35	30	4+4
F1032	150	65	30	4+4
F1033	180	35	35	4+4
F1034	180	60	35	4+4

配件 Parts : TCT刀片 : (1)15\*12\*1.5 (2)30\*12\*1.5 (3)40\*12\*1.5



### 可换刀片式修边刀 Interchangeable blade trimming knife

产品编号 Product Code	D 刀刃外径 Cutting Diameter	H 刀刃高度 Cutting Height	d 孔径 Aperture	z 齿数 Teeth Number
F1035	56	14	16/20	4
F1036	70	20	16/20	4
F1037	70	20	16/20	6
F1038	80	20	16/20	4
F1039	80	20	16/20	6

配件 Parts : TCT刀片 : (1)14\*14\*2 (2)20\*12\*1.5



### 可换刀片式修边刀 Interchangeable blade trimming knife

产品编号 Product Code	D 刀刃外径 Cutting Diameter	H 刀刃高度 Cutting Height	d 孔径 Aperture	z 齿数 Teeth Number	R 角度 Angle
F1040	56	12	16	4	2/3
F1041	58	12	16	4	2/3
F1042	70	20	20	4	2/3
F1043	69	13	16	4	2/3
F1044	75	16	16	4	2/3
F1045	75	16	16	6	2/3
F1046	75	16	20	4	2/3
F1047	77	13/16	20	4	2/3
F1048	78	19	16	4	2/3
F1049	80	20	20	4	2/3
F1050	80	20	20	6	2/3
F1051	82	16	20	4	2/3

配件 Parts : TCT刀片 : (1)16\*17\*2 (2)13\*4.5\*2.0



## 封边机预铣刀

### Banding Machine Pre-cutter

产品编号 Product Code	D 刀刃外径 Cutting Diameter	d 孔径 Aperture	H 刀刃高度 Cutting Height	z 齿数 Teeth Number
F8011	80	20	50	3+3
F8012	80	20	60	3+3
F8013	80	20	65	3+3

## 焊接式粗修刀

### The welded crude Dresser

产品编号 Product Code	D 刀刃外径 Cutting Diameter	d 孔径 Aperture	H 刀刃高度 Cutting Height	z 齿数 Teeth Number
F1001	80	20	20	4
F1002	80	20	20	6

## 焊接式精修刀

### Welded finishing knife

产品编号 Product Code	D 刀刃外径 Cutting Diameter	H 刀刃高度 Cutting Height	d 孔径 Aperture	z 齿数 Teeth Number	R 角度 Angle
F1003	75	16	16	4/6	1.5/2/3
F1004	75	16	20	4/6	1.5/2/3
F1005	77	13	20	4	2/3
F1006	78	19	16	4	2/3
F1007	80	20	20	4	2/3

## 焊接式圆弧双R封边刀

### Welding arc Double R Edge knife

产品编号 Product Code	D 外径 Cutting Diameter	H 刀刃高度 Cutting Height	d 孔径 Aperture	z 齿数 Teeth Number	R 圆弧 Circular Arc
F1008	68	16	16	6	2.0
F1009	68	16	16	6	3.0

## 焊接式精修刀

### Welded finishing knife

产品编号 Product Code	D 外径 Cutting Diameter	H 刀刃高度 Cutting Height	d 孔径 Aperture	z 齿数 Teeth Number	R 圆弧 Circular Arc
F1010	65	8	20	6	2.0/3.0
F1011	70	15	16/20	3/4	2.0/3.0
F1012	56	25	16	3	2.0/3.0
F1013	77.6	20	20	3/4	2.0/3.0

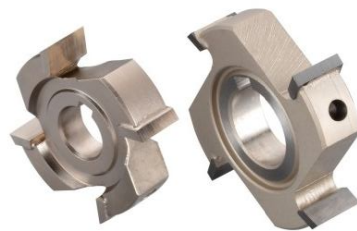

## 焊接式粗修刀

### The welded crude Dresser

产品编号 Product Code	D 刀刃外径 Cutting Diameter	d 孔径 Aperture	H 刀刃高度 Cutting Height	z 齿数 Teeth Number
F5601	56	16	14/15	4/6
F5602	56	20	14	4
F7001	70	16/20	14/16	4/6

## 焊接式精修刀

### Welded finishing knife

产品编号 Product Code	D 刀刃外径 Cutting Diameter	H 刀刃高度 Cutting Height	d 孔径 Aperture	z 齿数 Teeth Number	R 角度 Angle
F6901	69	13	16	4	1.5/2/3
F6902	69	13	20	4	1.5/2/3
F6903	69	13	16	6	1.5/2/3
F6904	69	13	20	6	1.5/2/3

## 焊接式跟踪刀

### The welded tracking knife

产品编号 Product Code	D 外径 Cutting Diameter	H 刀刃高度 Cutting Height	d 孔径 Aperture	z 齿数 Teeth Number	R 圆弧 Circular Arc
F7001	70	16	16	3/4	2.0/2.5
F7002	70	15	16	6	2.0/2.5
F7003	70	15	20	3/4	2.0/2.5

## 焊接式精修刀

### Welded finishing knife

产品编号 Product Code	D 刀刃外径 Cutting Diameter	H 刀刃高度 Cutting Height	d 孔径 Aperture	z 齿数 Teeth Number	R 角度 Angle
F5801	58	12	16	4	2/3
F6001	60	12	16	6	2/3
F7101	71	10	20	4/6	1.5/1.8/2.0

## 焊接式精修刀 Welded finishing knife

产品编号 Product Code	D 刀刃外径 Cutting Diameter	H 刀刃高度 Cutting Height	d 孔径 Aperture	z 齿数 Teeth Number	R 角度 Angle
F6002	60	12	16	6	双R2/3
F7001A	70	20	20	4	2/3
F7101	71	10	20/22	6	1.5/1.8/2
F7301	73	16	16	4	2/3
F7701	77	13	20	4	2/3
F7801	78	19	16	4	2/3
F8001	80	20	20	4	2/3
F8002	80	20	20	6	2/3
F8201	82	12/16	20	4	1.5/2/3

## 焊接式修边刀 The welded tracking knife

产品编号 Product Code	D 外径 Cutting Diameter	H 刀刃高度 Cutting Height	d 孔径 Aperture	z 齿数 Teeth Number	R 圆弧 Circular Arc
F6501	65	8	20	6	2.0/3.0
F7001B	70	15	16/20	3/4	2.0/3.0
F77601	70	27.5	16	4/6	2.0/3.0
F77602	77.6	20	20	3/4	2.0/3.0

## 焊接式修边刀 The welded tracking knife

产品编号 Product Code	D 外径 Cutting Diameter	H 刀刃高度 Cutting Height	d 孔径 Aperture	z 齿数 Teeth Number	R 圆弧 Circular Arc
F5801	58	18.5	16	6	2.0/3.0
F5801	58	18.5	16	6	2.5

## 可换刀片式修边刀 Interchangeable blade trimming knife

产品编号 Product Code	D 外径 Cutting Diameter	H 刀刃高度 Cutting Height	d 孔径 Aperture	z 齿数 Teeth Number	R 圆弧 Circular Arc
F6701	67	20/27	16	4	2.0/3.0
F6801	68	20/25	16	4	2.0/3.0
F7201	72	21/25	20	4	2.0/3.0

## 硬质合金锯片、金刚石锯片主锯 Carbide tipped saw blades, Diamond blade saw

产品编号 Product Code	D 外径 Cutting Diameter	B 刃厚 Blade thickness	d 孔径 Aperture	Z 齿数 Teeth Number
F10011	Φ350	3.5	30	72/84/96/120
F10012	Φ350	3.5	30	72/84/96/120
F10013	Φ350	3.5	25.4	72/84/96/120
F10014	Φ350	3.5	60	72/84/96/120
F10015	Φ350	3.5	60	72/84/96/120
F10016	Φ355	3.5	25.4	72/84/96/120
F10017	Φ355	3.5/3.6	25.4	72/84/96/120
F10018	Φ360	4.4	75	72/84/96/120
F10019	Φ360	4.4	75	72/84/96/120
F10020	Φ380	4.4	60	72/84/96/120
F10021	Φ380	4.4	60/80	72/84/96/120
F10022	Φ380	4.8	75	72/84/96/120
F10023	Φ380	4.8	60/80	72/84/96/120
F10024	Φ400	4.4	60/80	72/84/96/120
F10025	Φ400/405	4.0/4.4	60/80	72/84/96/120
F10026	Φ400	4.4	75	72/84/96/120
F10027	Φ400	4.4	75	72/84/96/120
F10028	Φ400	4.4	75	72/84/96/120
F10029	Φ430	4.4	75	72/84/96/120
F10030	Φ430	4.4	75	72/84/96/120
F10031	Φ430	4.4	75	72/84/96/120
F10032	Φ450	4.4	75	72/84/96/120
F10033	Φ450	4.4	75	72/84/96/120
F10034	Φ450	4.4	75	72/84/96/120
F10035	Φ450	4.8	60	72/84/96/120
F10036	Φ450	4.8	60	72/84/96/120
F10037	Φ450	4.8	60	72/84/96/120
F10038	Φ450	4.8	80	72/84/96/120
F10039	Φ450	4.8	80	72/84/96/120
F10040	Φ450	4.8	80	72/84/96/120



## 金刚石划线底锯片 Of diamond scribing bottom saw blade

产品编号 Product Code	D 外径 Cutting Diameter	B 刃厚 Blade thickness	d 孔径 Aperture	Z 齿数 Teeth Number
F10041	Φ120	2.8/3.6	20/22	12+12
F10042	Φ120	3.0/4.0	20/22	24
F10043	Φ150	3.3/4.3	30	36
F10044	Φ160	3.3/4.3	45	28
F10045	Φ160	4.3/5.3	45	28
F10046	Φ160	4.3/5.3	45	36
F10047	Φ176/180	3.3/4.3	25.4/30	36/40
F10048	Φ180	4.3/5.3	30	36
F10049	Φ180	4.3/5.3	45	36/40
F10050	Φ180	4.6/5.6	45	36
F10051	Φ180	4.6/5.6	75	36/40
F10052	Φ200	4.3/5.3	75	36/40
F10053	Φ200	4.6/5.6	75	36/40
F10054	Φ215	4.4/5.4	50.8	42

## 金刚石推台锯专用锯片 Special saw blade diamond sliding table saw

产品编号 Product Code	D 外径 Cutting Diameter	B 刃厚 Blade thickness	d 孔径 Aperture	Z 齿数 Teeth Number
F10067	Φ300	3.2	25.4/30	60
F10068	Φ300	3.2	25.4/30	72
F10069	Φ300	3.2	25.4/30	96
F10070	Φ350	3.5	25.4/30	72
F10071	Φ350	3.5	25.4/30	84/96
F10072	Φ350	3.5	25.4/30	96
F10073	Φ380	3.5/3.7	25.4/30	84/96

## 地板分条机金刚石锯片 Floor slitting machine diamond saw blade

产品编号 Product Code	D 外径 Cutting Diameter	B 刃厚 Blade thickness	d 孔径 Aperture	Z 齿数 Teeth Number
F10055	Φ200	1.8/2.2	25.4/30/60	24/36
F10056	Φ200	2.1/2.6	30/35/50	24/36
F10057	Φ200	1.6/2.0/2.4	25.4/30/40	24/36
F10058	Φ230	1.5/2.0/2.2	60	40
F10059	Φ230	1.8/2.5	60	48
F10060	Φ230	2.0/2.6/3.0	60	48
F10061	Φ250	2.4/3.0	60	48
F10062	Φ250	2.5/3.0/3.2	60	60
F10063	Φ250	2.6/3.0	80	48
F10064	Φ250	2.6/3.0/3.2	80	60
F10065	Φ300	2.8/3.0/3.2	30/60/80	60
F10066	Φ300	3.0	30/40/80	72
F10067	Φ300	2.5/3.0/3.2	74	60
F10068	Φ300	2.6/3.2	80	60
F10069	Φ300	2.8/3.0/3.2	80	72

## 金刚石开槽锯片(封边机开槽锯片) Diamond slotting saw blades

产品编号 Product Code	D 外径 Cutting Diameter	B 刃厚 Blade thickness	d 孔径 Aperture	Z 齿数 Teeth Number
F10074	Φ80	1.5/1.8	25.4/30/35	12
F10075	Φ80	2.0/2.4	25.4/30/35	12
F10076	Φ100	1.6/1.8	25.4/30/35	12
F10077	Φ100	2.0/2.5	25.4/30/35	12
F10078	Φ125	1.6/1.8	25.4/30/35	18
F10079	Φ125	2.0/2.6	25.4/30/35	18
F10080	Φ125	3.0/3.2	25.4/30/35	18
F10081	Φ125	3.5	25.4/30/35	18
F10082	Φ125/135	4.0	25.4/30/35	18/24
F10083	Φ125/140	4.5	25.4/30/35	18/24
F10084	Φ125/150	5.0	25.4/30/35	18/24
F10085	Φ125/160	5.5	25.4/30/35	18/24
F10086	Φ125/160	6.0	25.4/30/35	18/24

## 金刚石双端铣锯片 The diamond sliding table saw blade

产品编号 Product Code	D 外径 Cutting Diameter	B 刃厚 Blade thickness	d 孔径 Aperture	Z 齿数 Teeth Number
F10087	Φ250	4.0	80	48
F10088	Φ250/300	4.2/4.4	80	56
F10089	Φ250/300	4.0/4.4	80/130	48
F10090	Φ250/300	4.2/4.4	80/130	60
F10091	Φ250/300	4.2/4.4	80/130	72

## 音箱业专用金刚石锯片 Diamond saw blades for the speaker industry



产品编号 Product Code	D 外径 Cutting Diameter	B 刃厚 Blade thickness	d 孔径 Aperture	Z 齿数 Teeth Number
F10092	Φ180	2.0	25.4	24
F10093	Φ180	2.2	25.4	24
F10094	Φ180	2.6	40	24
F10095	Φ200	2.0	35	24
F10096	Φ200	2.5	40	30
F10097	Φ230	2.2	25.4	36/48
F10098	Φ230	3.0	25.4	60
F10099	Φ230	2.5	30	60
F10100	Φ250	3.0	25.4	48
F10101	Φ250	3.2	30	60
F10102	Φ250	3.2	25.4	60
F10103	Φ255	3.0	25.4	60
F10104	Φ280	3.0	25.4	72
F10105	Φ280	3.0	25.4	80
F10106	Φ280	3.0	25.4	90
F10107	Φ280	3.0	25.4	48+24
F10108	Φ280	3.0	25.4	36+36
F10109	Φ305	3.0	25.4	60
F10110	Φ305	3.0	25.4	80
F10111	Φ350	3.0	25.4	100
F10112	Φ355	3.0	25.4	60
F10113	Φ355	3.0	25.4	72
F10114	Φ355	3.0	25.4	80

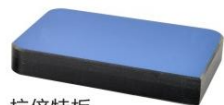

抗倍特板

## 抗倍特板、电木集层板用金刚石锯片 Combent board, bakelite set of shelves with a diamond saw blade

产品编号 Product Code	D 外径 Cutting Diameter	B 刃厚 Blade thickness	d 孔径 Aperture	Z 齿数 Teeth Number
F10115	Φ250	3.0/3.2	25.4/30	48/60
F10116	Φ300	3.2/3.5	30	60/72
F10117	Φ300	4.0	30	72
F10118	Φ350	3.5	30	72
F10119	Φ350/355	3.5	25.4/30	72/84
F10120	Φ350/355	4.0	25.4/30	72/80
F10121	Φ400	4.4	60/75	72/84/96
F10122	Φ430	4.4	60/75	72/84/96
F10123	Φ450	4.8	60/75	72/84/96



## 亚克力/有机玻璃专用锯片 Acrylic / plexiglass special saw blade

产品编号 Product Code	D 外径 Cutting Diameter	B 刃厚 Blade thickness	d 孔径 Aperture	Z 齿数 Teeth Number
T2051	Φ205	1.2/1.6	25.4	100
T2052	Φ205	2.0	25.4	100
T25501	Φ255	2.0	25.4	100
T25502	Φ255	2.2	25.4	100
T25503	Φ255	3.0	25.4	100/120
T30501	Φ305	2.6/3.0	25.4	60
T30502	Φ305	2.0	25.4	80
T30503	Φ305	3.0	25.4	80
T30504	Φ305	2.0/3.0	25.4	100
T30505	Φ305	3.0	25.4	100
T30506	Φ305	2.6	25.4	120
T30507	Φ305	3.0	25.4	120
T30508	Φ305	2.0/3.0	25.4	100/120
T35501	Φ355	3.0	25.4	60
T35502	Φ355	3.0	25.4	80
T35503	Φ355	3.0	25.4	100/120
T35504	Φ355	3.2/3.5	25.4	100/120

## 相框专用锯片 (适用实木、石膏、塑胶、复合材料锯切) Frame special saw blade (for wood, plaster, plastic, composite materials sawing)

产品编号 Product Code	D 外径 Cutting Diameter	B 刃厚 Blade thickness	d 孔径 Aperture	Z 齿数 Teeth Number
T2051	Φ205	1.2/1.6	25.4	100
T2052	Φ205	2.0	25.4	100
T25501	Φ255	2.0	25.4	100
T25502	Φ255	2.2	25.4	100
T25503	Φ255	3.0	25.4	100/120
T30503	Φ305	2.0/3.0	25.4	80
T30504	Φ305	2.0	25.4	100
T30505	Φ305	2.6	25.4	100
T30506	Φ305	3.0	25.4	100
T30507	Φ305	3.0	25.4	120
T35501	Φ355	2.0	25.4	100
T35502	Φ355	2.6	25.4	100
T35503	Φ355	3.0	25.4	100
T35504	Φ355	3.0	25.4	120

## 推台锯锯片/电子开料锯锯片 Push the table saw blade/electronic cutting saw blade



产品编号 Product Code	D 外径 Cutting Diameter	B 刃厚 Blade thickness	d 孔径 Aperture	Z 齿数 Teeth Number
T16010	Φ120	3.0/4.0	20	24
T16011	Φ120	3.0/4.0	22	24
T16012	Φ120	2.8/3.6	20	12+12
T16013	Φ120	2.8/3.6	22	12+12
T16014	Φ300	3.2	30	32
T16015	Φ300	3.2	30	48
T16016	Φ300	3.2	30	60
T16017	Φ300	3.2	30	72
T16018	Φ300	3.2	30	96
T16019	Φ305	4.0	25.4/30	48
T16020	Φ350	3.5	25	72
T16021	Φ350	3.5	30	84
T16022	Φ350	3.5	30	96
T16023	Φ350	3.8	30	84
T16024	Φ350	4.4	30	72/84
T16025	Φ350	4.4	60	72/84
T16026	Φ380	4.4	75	72/84
T16027	Φ380	4.4	60	96
T16028	Φ380	4.8	60	72/84
T16029	Φ400	4.4	60	72/84
T16030	Φ400	4.4	60	96/108
T16031	Φ400	4.4	75	72/84
T16032	Φ400	4.4	75	96/108
T16033	Φ400	4.4	80	72/84
T16034	Φ400	4.4	60/80	96
T16035	Φ430	4.4	75	72/84
T16036	Φ430	4.4	75	96
T16037	Φ450	4.8	60/80	72/84
T16038	Φ450	4.8	60/80	96/108
T16039	Φ520	5.0	70	72/84
T16040	Φ600	6.0	60	72/84
T16041	Φ730	6.8	80	72/84
T16042	Φ860	7.0	80	84/96
T16043	Φ125	4.3/5.3	45	24
T16044	Φ150	4.3/5.3	30/45	36
T16045	Φ160	4.3/5.3	45	28/36
T16046	Φ180	3.3/4.3	25.4/30	40
T16047	Φ180	4.3/5.3	30/45	40
T16048	Φ180	4.6/5.6	30/45	36/40
T16049	Φ200	4.3/5.3	75	36/40
T16050	Φ200	4.6/5.6	45	36/40
T16051	Φ200/Φ215	4.3/5.3	50	40
T16052	Φ300	4.3/5.3	50	48

## 双贴面螺旋开料刀 Double-faced spiral cutter

产品编号 Product Code	D 柄径 Shank diameter	d 刃径 Cutting Diameter	H 刀长 Knife length	L 全长 Total length
T011	1/2	6mm	20mm	65
T011	1/2	6mm	22mm	70
T011	1/2	6mm	24mm	70
T011	1/2	6mm	26mm	70
T011	1/2	6mm	28mm	70
T011	1/2	6mm	30mm	70
T011	1/2	8mm	20mm	70
T011	1/2	8mm	22mm	70
T011	1/2	8mm	24mm	70
T011	1/2	8mm	26mm	70
T011	1/2	8mm	28mm	70
T011	1/2	8mm	30mm	70
T011	1/2	10mm	30mm	70



## 三刃断屑开料刀 Three-edge chip cutter

产品编号 Product Code	D 柄径 Shank diameter	d 刃径 Cutting Diameter	H 刀长 Knife length	L 全长 Total length
T008	1/2	5mm	20mm	65
T008	1/2	6mm	20mm	65
T008	1/2	6mm	22mm	70
T008	1/2	6mm	25mm	70
T008	1/2	6mm	26mm	70
T008	1/2	6mm	28mm	70
T008	1/2	6mm	30mm	70
T008	1/2	7mm	20mm	70
T008	1/2	7mm	30mm	70
T008	1/2	8mm	20mm	65
T008	1/2	8mm	20mm	65
T008	1/2	8mm	22mm	70
T008	1/2	8mm	25mm	70
T008	1/2	8mm	26mm	70
T008	1/2	8mm	28mm	70
T008	1/2	8mm	30mm	70
T008	1/2	8mm	32mm	75
T008	1/2	8mm	40mm	80
T008	1/2	10mm	20mm	70
T008	1/2	10mm	30mm	75
T008	1/2	10mm	40mm	80
T008	1/2	12mm	20mm	70





### 三刃开料刀 (直刀) Three-point cutter (straight cutter)

产品编号 Product Code	D 柄径 Shank diameter	d 刃径 Cutting Diameter	H 刀长 Knife length	L 全长 Total length
T007	1/2	5mm	20mm	65
T007	1/2	6mm	20mm	65
T007	1/2	6mm	22mm	70
T007	1/2	6mm	25mm	70
T007	1/2	6mm	26mm	70
T007	1/2	6mm	28mm	70
T007	1/2	6mm	30mm	70
T007	1/2	7mm	20mm	70
T007	1/2	7mm	30mm	70
T007	1/2	8mm	20mm	65
T007	1/2	8mm	20mm	65
T007	1/2	8mm	22mm	70
T007	1/2	8mm	25mm	70
T007	1/2	8mm	26mm	70
T007	1/2	8mm	28mm	70
T007	1/2	8mm	30mm	70
T007	1/2	8mm	32mm	75
T007	1/2	8mm	40mm	80
T007	1/2	10mm	20mm	70
T007	1/2	10mm	30mm	75
T007	1/2	10mm	40mm	80
T007	1/2	12mm	20mm	70



### TCT直刀 TCT straight knife

产品编号 Product Code	D 柄径 Shank diameter	d 刃径 Cutting Diameter	H 刀长 Knife length	L 全长 Total length
T005	1/2	2mm	4-8mm	60
T005	1/2	2.5mm	8mm	
T005	1/2	3mm	8-15mm	
T005	1/2	3.5mm	8-15mm	
T005	1/2	4mm	10-15mm	
T005	1/2	4.5mm	10-20mm	
T005	1/2	5mm	10-20mm	
T005	1/2	5.5mm	15mm	
T005	1/3	6mm	10-28mm	
T005	1/4	7mm	10-28mm	
T005	1/5	8mm	10-40mm	
T005	1/6	9mm	10-40mm	
T005	1/7	10mm	10-40mm	



### 左旋 Left Rotation



F

### 右旋 Right Rotation



A

### 整体型合金排钻

#### Overall type alloy drilling row

产品编号 Product Code	D 刃径 Cutting Diameter	B (MM)	L 全长 Total length
10357R/L	Φ3.0	18/20	57/70
104057R/L	Φ4.0	27/38	57/70
105057R/L	Φ5.0	27/38	57/70
106057R/L	Φ6.0	27/38	57/70
107057R/L	Φ7.0	27/38	57/70
108057R/L	Φ8.0	27/38	57/70
109057R/L	Φ9.0	27/38	57/70
101057R/L	Φ10.0	27/38	57/70
101157R/L	Φ11.0	27/38	57/70
101257R/L	Φ12.0	27/38	57/70
101357R/L	Φ13.0	27/38	57/70
101457R/L	Φ14.0	27/38	57/70
101557R/L	Φ15.0	27/38	57/70
101657R/L	Φ16.0	27/38	57/70

### 左旋 Left Rotation

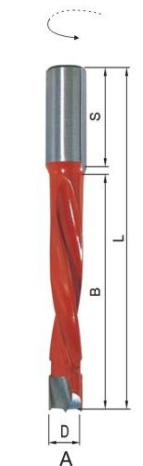

H

### 右旋 Right Rotation



A

### 加长整体型合金排钻

#### Overall type alloy drilling row

产品编号 Product Code	D 刃径(mm) Cutting Diameter	L 全长(mm) Total length
10510R/L	Φ5.0	80/100
10610R/L	Φ6.0	80/100
10710R/L	Φ7.0	80/100
10810R/L	Φ8.0	80/100
10910R/L	Φ9.0	80/100
101012R/L	Φ10.0	80/100/120
101212R/L	Φ12.0	80/100/120
101412R/L	Φ14.0	80/100/120
101512R/L	Φ15.0	80/100/120
101612R/L	Φ16.0	100/120/160

右旋  
Right Rotation

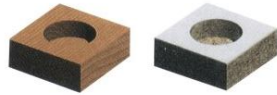

### 分体型合金排钻 Sub-size alloy drilling row

产品编号 Product Code	D 刃径 Cutting Diameter	L 全长 Total length
101557R/L	$\Phi 15.0$	57/70
101657R/L	$\Phi 16.0$	57/70
101757R/L	$\Phi 17.0$	57/70
101857R/L	$\Phi 18.0$	57/70
101957R/L	$\Phi 19.0$	57/70
102057R/L	$\Phi 20.0$	57/70
102157R/L	$\Phi 21.0$	57/70
102257R/L	$\Phi 22.0$	57/70
102357R/L	$\Phi 23.0$	57/70
102457R/L	$\Phi 24.0$	57/70
102557R/L	$\Phi 25.0$	57/70
102657R/L	$\Phi 26.0$	57/70
102757R/L	$\Phi 27.0$	57/70
102857R/L	$\Phi 28.0$	57/70
102957R/L	$\Phi 29.0$	57/70
103057R/L	$\Phi 30.0$	57/70
103157R/L	$\Phi 31.0$	57/70
103257R/L	$\Phi 32.0$	57/70
103357R/L	$\Phi 33.0$	57/70
103457R/L	$\Phi 34.0$	57/70
103557R/L	$\Phi 35.0$	57/70
103657R/L	$\Phi 36.0$	57/70
103757R/L	$\Phi 37.0$	57/70
103870R/L	$\Phi 38.0$	57/70
103970R/L	$\Phi 39.0$	57/70
104070R/L	$\Phi 40.0$	57/70
104270R/L	$\Phi 42.0$	57/70
104870R/L	$\Phi 48.0$	57/70
105070R/L	$\Phi 50$	70
106070R/L	$\Phi 60$	70
106570R/L	$\Phi 65$	70

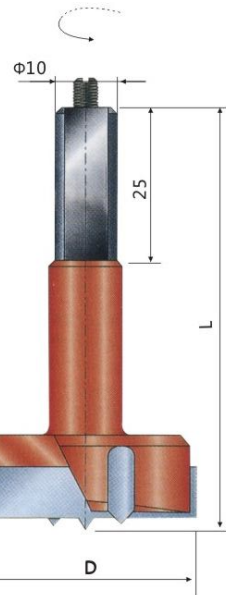

左旋  
Left Rotation

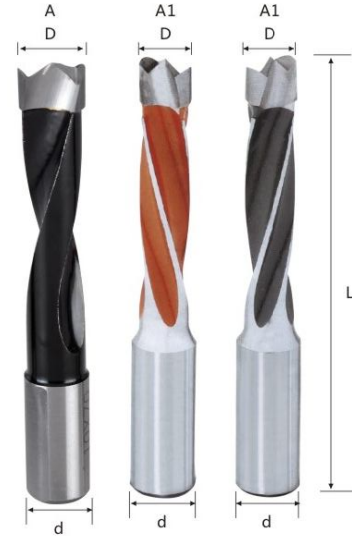

左旋  
Left Rotation

右旋  
Right Rotation

- ▶ 超细微颗粒整体钨钢头，完美演绎其物理特性，有效提高钻孔效率及大幅提升钻孔数量。
- ▶ 榫孔式钻头尖能把钻头锁定在固定的定位点上，防止滑动。
- ▶ 采用进口特殊涂料工艺，减少钻孔的摩擦力并提供良好的排屑能力。
- ▶ 两侧特殊刮刀设计确保钻孔的完美，并可防止崩边。
- ▶ 特殊主副槽排屑设计，有效提高刀具稳定度。

### 高效整体型合金排钻 Efficient overall alloy drilling row

产品编号 Product Code	D 刃径(mm) Cutting Diameter	d 柄径(mm) Handle Diameter	L 全长(mm) Total Length
F1031057R/L	$\Phi 3.0$	10	57/70
F1041057R/L	$\Phi 4.0$	10	57/70
F1051057R/L	$\Phi 5.0$	10	57/70
HG1061057R/L	$\Phi 6.0$	10	57/70
F1071057R/L	$\Phi 7.0$	10	57/70
F1081057R/L	$\Phi 8.0$	10	57/70
F1091057R/L	$\Phi 9.0$	10	57/70
F10101057R/L	$\Phi 10.0$	10	57/70
F10111057R/L	$\Phi 11.0$	10	57/70
F10121057R/L	$\Phi 12.0$	10	57/70
F10131057R/L	$\Phi 13.0$	10	57/70
F10141057R/L	$\Phi 14.0$	10	57/70
F10151057R/L	$\Phi 15.0$	10	57/70
F10161057R/L	$\Phi 16.0$	10	57/70

### 通孔排钻(V型) Through-hole drilling row (V type)

产品编号 Product Code	D 刃径(mm) Cutting Diameter	d 柄径(mm) Handle Diameter	L 全长(mm) Total Length
F1031057R/L	$\Phi 3.0$	10	57/70
F1041057R/L	$\Phi 4.0$	10	57/70
F1051057R/L	$\Phi 5.0$	10	57/70
F1061057R/L	$\Phi 6.0$	10	57/70
F1071057R/L	$\Phi 7.0$	10	57/70
F1081057R/L	$\Phi 8.0$	10	57/70
F1091057R/L	$\Phi 9.0$	10	57/70
F10101057R/L	$\Phi 10.0$	10	57/70
F10111057R/L	$\Phi 11.0$	10	57/70
F10121057R/L	$\Phi 12.0$	10	57/70
F10131057R/L	$\Phi 13.0$	10	57/70
F10141057R/L	$\Phi 14.0$	10	57/70
F10151057R/L	$\Phi 15.0$	10	57/70
F10161057R/L	$\Phi 16.0$	10	57/70



特级高切削性能，钻更精准的孔，更耐用，不崩口。

## 整体钨钢钻头

The overall tungsten steel drill bit

产品编号 Product Code	D 刃径(mm) Cutting Diameter	d 柄径(mm) Handle Diameter	L 全长(mm) Total Length
F301R/L	Φ3.0	10	57/70
F401R/L	Φ4.0	10	57/70
F501R/L	Φ5.0	10	57/70
F601R/L	Φ6.0	10	57/70
F701R/L	Φ7.0	10	57/70
F801R/L	Φ8.0	10	57/70
F901R/L	Φ9.0	10	57/70
F1001R/L	Φ10.0	10	57/70
F1002R/L	Φ11.0	10	57/70
F1003R/L	Φ12.0	10	57/70

## 高效分体型合金排钻

Efficient sub-size alloy drilling row

产品编号 Product Code	D 刃径 Cutting Diameter	L 全长 Total Length
F101557R/L	Φ15.0	57/70
F101657R/L	Φ16.0	57/70
F101757R/L	Φ17.0	57/70
F101857R/L	Φ18.0	57/70
F101957R/L	Φ19.0	57/70
F102057R/L	Φ20.0	57/70
F102157R/L	Φ21.0	57/70
F102257R/L	Φ22.0	57/70
F102357R/L	Φ23.0	57/70
F102457R/L	Φ24.0	57/70
F102557R/L	Φ25.0	57/70
F102657R/L	Φ26.0	57/70
F102757R/L	Φ27.0	57/70
F102857R/L	Φ28.0	57/70
F102957R/L	Φ29.0	57/70
F103057R/L	Φ30.0	57/70
F103157R/L	Φ31.0	57/70
F103257R/L	Φ32.0	57/70
F103357R/L	Φ33.0	57/70
F103457R/L	Φ34.0	57/70
F103557R/L	Φ35.0	57/70
F103657R/L	Φ36.0	57/70
F103757R/L	Φ37.0	57/70
F103857R/L	Φ38.0	57/70
F103957R/L	Φ39.0	57/70
F104057R/L	Φ40.0	57/70

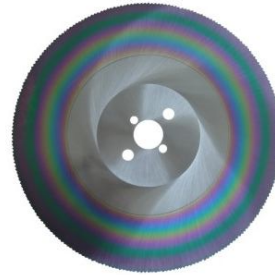

## 高速钢(HSS)锯片

High-speed steel (HSS) saw blades

产品编号 Product Code	D 外径 Cutting Diameter	B 刃厚 Blade thickness	d 孔径 Aperture	Z 齿数 Teeth Number
F200163216	Φ200	1.6	32	160
F200163220	Φ200	1.6	32	200
F225163220	Φ225	1.6	32	200
F225163222	Φ225	1.6	32	220
F250163224	Φ250	1.6	32	240
F250203224	Φ250	2.0	32	240
F275163222	Φ275	1.6	32	220/240
F275203222	Φ275	2.0	32	220/240
F275203224	Φ275	2.0	32	240/260
F300163224	Φ300	1.6	32	240/260
F300203224	Φ300	2.0	32	240/260
F315163224	Φ315	1.6	32	240/260
F315203224	Φ315	2.0	32	240/260
F315253224	Φ315	2.5	32	240/260
F325163224	Φ325	1.6	32	240/260
F325203224	Φ325	2.0	32	240/260
F325253224	Φ325	2.5	32	240/260
F350203224	Φ350	2.0	32	240/260
F350253228	Φ350	2.5	32	280

适用锯切：201和304不锈钢管材和厚壁焊管，无缝钢管，槽钢，型钢、棒料和铝件。

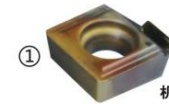

① 机夹式单晶钻石刀



② 金刚石PCD粗抛刀/精抛刀

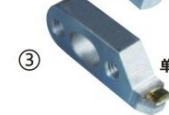

③ 单晶钻石精抛刀

## 抛光刀

Polishing knife

产品编号 Product Code	L 总长 Total length	B 宽度 Width	H 厚度 Thickness	α 角度 Angle
F3301	33	12	5	90
F3302	33	12	5	120
F3303	33	12	5	140
F3304	33	12	5	160
F3305	28	12	6	140
F3306	28	12	6	160

左旋  
Left Rotation

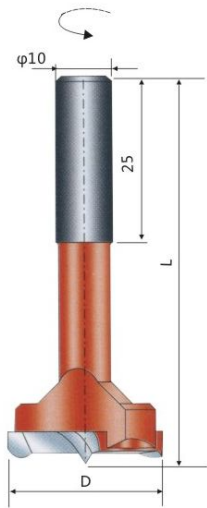

右旋  
Right Rotation

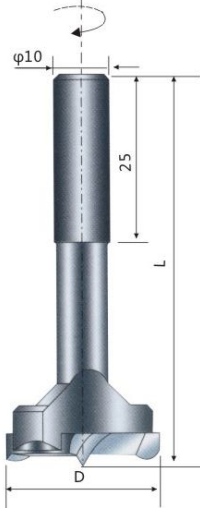

主要用于:天然木料,合成木料,中纤板,刨花板,胶合板,木门锁孔加工等。  
 特点:木料加工专用刀具,此类刀具用于加工木料及合成木料  
 碎屑排除方便,刀体坚固,经久耐用,加工效果好表面无毛刺  
 Applications:Wood Composites MDF,  
 Plywood,Laminates,Hardwoods

### 三刃全钨钢粗铣刀上旋/下旋 Three Flute Solid Carbide Chipbreaker Finisher-Upcut/Downcut

产品编号 Product Code	D 刀刃外径 Cutting Diameter	L1 刃长 Cutting Length	d 柄径 Shank Diameter	L 总长 Total length
T1601	8	22	8	80
T1602	10	32	10	80
T1603	10	42	10	100
T1604	12	32	12	80
T1605	12	42	12	100
T1607	14	42	14	100
T1608	16	42	16	100
T1609	16	52	16	120
T1610	16	60	16	130
T1611	16	70/80	16	150/170
T1612	20	80/100	20	190/200
T1613	20	120/140	20	170/200

### CNC超微粒整体硬质合金双刃螺旋

CNC superfine grain cemented carbide  
 as a whole Double spiral

产品编号 Product Code	D 刀刃外径 Cutting Diameter	L1 刃长 Cutting Length	d 柄径 Shank Diameter	L 总长 Total length
T1220	3.175	12	3.175	40
T1221	3.175	15	3.175	40
T1222	4	12	4	45
T1223	4	17	4	45
T1224	4	22	4	50
T1225	5	17	5	50
T1226	5	22	5	50
T1227	6	17	6	50
T1228	6	22	6	60
T1229	8	25	8	70
T1230	8	35	8	80
T1231	10	35	10	80
T1232	12	35	12	80
T1233	14	50	14	90
T1234	16	55	16	100
T1235	18	60	18	120
T1236	20	60	20	120



01 02 03

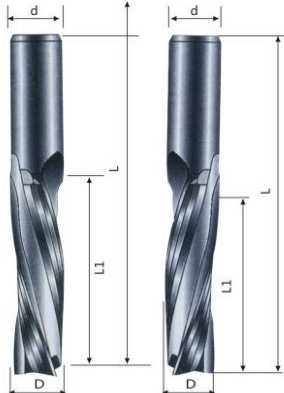
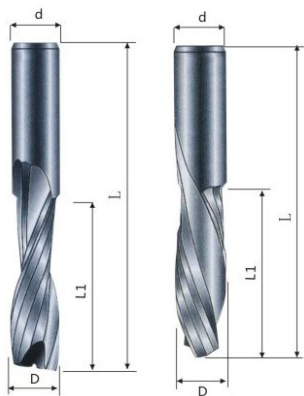

### 三刃全钨钢精铣刀上旋/下旋 Three Flute Solid Carbide Chipbreaker Finisher-Upcut/Downcut

产品编号 Product Code	D 刀刃外径 Cutting Diameter	L1 刃长 Cutting Length	d 柄径 Shank Diameter	L 总长 Total length
T801	8	22	8	80
T802	10	32	10	80
T803	10	42	10	100
T804	12	32	12	80
T805	12	42	12	100
T806	14	42	14	100
T807	16	42	16	100
T808	16	52	16	120

### CNC 超微粒整体硬质合金复合刃铣刀 CNC Micro Grain Total Carbide Composite Blade End Mill

产品编号 Product Code	D 刀刃外径 Cutting Diameter	L1 刃长 Cutting Length	d 柄径 Shank Diameter	L 总长 Total length
T1251	4	12	4	50
T1252	4	17	4	50
T1253	5	17	5	50
T1254	5	22	5	50
T1255	6	17	6	50
T1256	6	22	6	50
T1257	6	35	6	70
T1258	8	35	8	80
T1259	10	45	10	90

### TCT整体硬质合金螺旋/直刀 TCT solid carbide straight knife/spiral

产品编号 Product Code	d 柄径 Shank Diameter	D 刀刃外径 Cutting Diameter	L1 刃长 Cutting Length	L 总长 Total length	
T1260	6(1/4)	12(1/2)	3	10/12	50
T1261	6(1/4)	12(1/2)	4	10/12/15	50
T1262	6(1/4)	12(1/2)	5	15/20/25	55
T1263	6(1/4)	12(1/2)	6	18/20/25	60
T1264	6(1/4)	12(1/2)	8	25/30/35	60
T1265	6(1/4)	12(1/2)	3	10/12	50
T1266	6(1/4)	12(1/2)	4	10/12/15	50
T1270	6(1/4)	12(1/2)	5	15/20/25	55
T1271	6(1/4)	12(1/2)	6	20/25/30	60
T1272	6(1/4)	12(1/2)	8	20/25/30	70/80
T1273	6(1/4)	12(1/2)	10	30/35/45	70/80





排钻头

接头



A接头

B-12十字  
B-14

黑色B-14, 40MM十字

白色B-14, 45mm一字



D型M8

C型M10正牙

C型M8反牙

M8-1

M8-2



E型

F型

H型

G型

**外牙特殊钻头**  
Threaded Shank Solid Drills

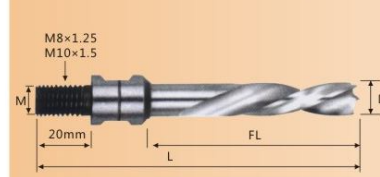

**直柄钻头**  
Straight Shank Solid Drills

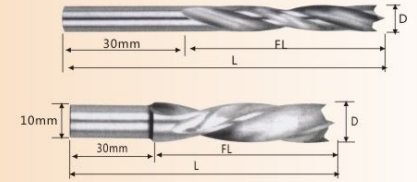

**组合外牙特殊钻头**  
Threaded Shank Solid Drills With Integral Adapter



**杯型刀**  
Cup type knife



**外牙双层钻头**  
Threaded Shank Solid Step Drills

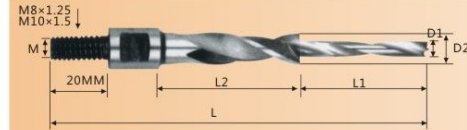

**直柄双层钻头**  
Straight Shank Solid Step Drills

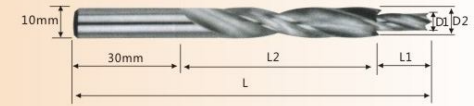

**组合外牙沙拉外套**  
Threaded Integral Salad Adapter

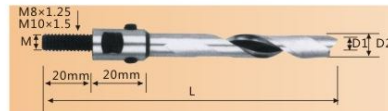

**组合沙拉外套**  
Integral Salad Adapter



**榫槽刀**  
Straight Shank Solid Mortising Bits

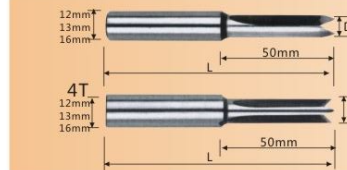

**取木塞钻头**  
Wood Plug Extractors

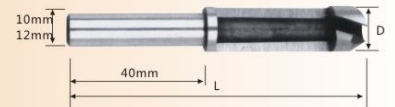

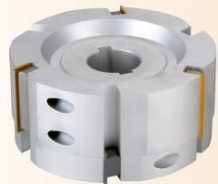

F801

可换刀片式预铣刀



F802

可换刀片式预铣刀



F803

可换刀片式平刀



F804

可换刀片式修边刀



F805

可换刀片式修边刀



F806

可换刀片式修边刀



F807

可换刀片式预铣刀



F808

V型刀  
30°/45°/60°/90°



F809

半圆R刀



F810

成型线刀



F811

平口刀

可订制各种  
异型刀具



F501

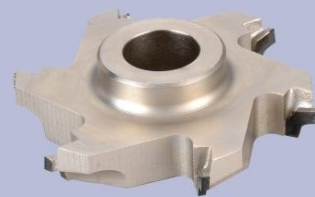

F502



F503



F504

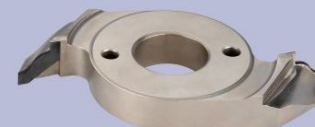

F505



F506



F507



F508



F509

100x24x25x6T R9/10/11/12



F511

100x19x25x6T R6/7/8/10



F512